

# PowerCore Battery Cabinet User Manual

---



**Copyright © Jiangsu Weiheng Intelligent Technology Co., Ltd. All rights reserved.**

Unauthorized excerpts, reproduction or distribution in any form, in whole or in part, of this document by any organization or individual without Weiheng's written consent is strictly prohibited.

### **Trademark Statement**

**UHE S** and other WEIHENG trademarks are owned by Jiangsu Weiheng Intelligent Technology Co., Ltd. All other trademarks or registered trademarks referenced herein are the property of their respective owners.

**Note:** Your purchase of the products, services or features is subject to WEIHENG's commercial contracts and terms and conditions. As a result, all or part of the products, services or features described in this document may not be consistent with your specific purchase or use. Unless otherwise agreed in the contract, WEIHENG makes no statements or warranties, express or implied, with respect to the contents of this document.

This document may be updated from time to time due to product version upgrades or other factors. Unless otherwise agreed, this document is provided as a guide only and no representations, information or recommendations contained herein constitute a warranty of any kind, either express or implied.

## **Jiangsu Weiheng Intelligent Technology Co., Ltd.**

Address: Luoshe Town, Huishan District, Wuxi, Jiangsu Province, China (at the intersection of Jianghai West Road and Luonan Avenue)

Postal Code: 214000

Website: [www.whes.com](http://www.whes.com)

# Introduction

## Overview






This document provides guidance on the installation, electrical connection, commissioning, and troubleshooting methods for the DC-500kWh-EA10 energy storage battery cabinet (hereinafter referred to as the "energy storage system"). Prior to installation, operation of the energy storage system (ESS), please read this manual carefully, ensuring comprehension of the safety information and familiarity with the system's functions and features.

## Users

This manual is applicable to power station operators and qualified electrical technicians.

## Symbol Convention

In this document, the following symbols may be used with the meanings described below.

Symbol	Description
	It indicates a hazard with a high level of risk that, if not avoided, will result in death or serious injury.
	It indicates a hazard with a moderate level of risk that, if not avoided, could result in death or serious injury.
	It indicates a hazard with a low level of risk that, if not avoided, could cause minor or moderate injury.
	It is used to convey warning information related to equipment or environmental safety. If not avoided, it may result in damage to equipment, loss of data, degradation of equipment performance, or other unpredictable consequences. The "BEWARE" symbol does not refer to personal injury.
	It is used to emphasize important/critical information, best practices, and tips. The "NOTE" symbol is not a safety warning and does not refer to personal injury, equipment damage, or environmental hazards.

## **Modification Record**

The revision history tracks the description of all updates to the document. The latest version of the document contains all changes from previous revisions.

### **Document Edition: 01 (2025-1-20)**

V1.0

# Table of Contents

<b>Introduction</b> .....	<b>iii</b>
<b>1 Safety Precautions</b> .....	<b>1</b>
1.1 General Safety .....	1
1.2 Personnel Requirements .....	5
1.3 Storage and Installation Environment Requirements.....	7
1.4 Loading/Unloading and Transport Requirements .....	10
1.5 Electrical Safety.....	12
1.6 Mechanical Safety.....	14
1.7 Battery Safety.....	17
1.8 Maintenance .....	22
1.9 Emergency Procedures.....	23
<b>2 Product Introduction</b> .....	<b>24</b>
2.1 Model Description .....	24
2.2 Functions and Features .....	24
2.3. Appearance .....	26
2.4 Components.....	27
2.5. Working Principle.....	41
2.6 Application Scenarios.....	42
<b>3 Site Requirements</b> .....	<b>43</b>
3.1 Site Selection Requirements .....	43
3.2 Forklift Requirements .....	44
<b>4 Equipment Installation</b> .....	<b>45</b>
4.1 Pre-Installation Preparation.....	45
4.2 Installing the ESS and Cables .....	49
<b>5 System Power-On</b> .....	<b>61</b>
5.1 Pre-Power-On Inspection.....	61
<b>6 Power-On Commissioning (PANGU-LITE)</b> .....	<b>63</b>
6.1 Preparation and PANGU LITE Access .....	63
6.2 HMI Description.....	64
6.3 Startup Procedure.....	69
6.4 Shutdown Procedure.....	70
<b>7 Technical Data</b> .....	<b>71</b>

---

<b>8. Product Maintenance .....</b>	<b>73</b>
8.1 Terminology Definition .....	73
8.2 Requirements for Normal System Operation .....	73
8.3 Requirements for Intermittent System Operation .....	73
8.4 Requirements for Long-Term System Storage .....	73
8.5 Battery Maintenance Instructions.....	74
8.6 Liquid Cooling System Maintenance and Service Requirements .....	75
<b>A Crimping OT/DT Terminals .....</b>	<b>76</b>
<b>B How to Repaint.....</b>	<b>79</b>
<b>C How to Recycle Used Batteries .....</b>	<b>84</b>
<b>D Contact Details .....</b>	<b>85</b>
<b>E Abbreviations.....</b>	<b>86</b>
<b>F Install.....</b>	<b>87</b>
<b>Appendix 1 .....</b>	<b>92</b>

# 1 Safety Precautions

## 1.1 General Safety

### Declaration

Please thoroughly read this manual before installing, operating, and maintaining the equipment, and follow the markings present on the equipment, as well as all safety precautions outlined in this manual.

The "BEWARE", "CAUTION", "WARNING", and "DANGER" instructions contained in this manual do not cover all safety considerations that need to be observed, but are only intended to supplement all safety precautions. Weiheng disclaims any liability for damages resulting from failure to comply with general safe operation requirements or from violation of safety standards applicable to the design, production, and use of the equipment.

This equipment must be used in an environment that meets the design specifications, otherwise the equipment may fail, resulting in equipment malfunctions, component damage, personal safety accidents, property losses, etc., which are not covered by the quality warranty.

Be sure to install, operate and maintain the equipment in accordance with local laws, regulations, and specifications. The safety precautions contained in this manual are intended only to supplement local laws and regulations.

Weiheng shall not be held liable in any of the following circumstances:

- Installing or operating the equipment in an environment that exceeds applicable international, national, or local standards;
- Failure to operate the equipment under the conditions specified in this manual;
- Unauthorized disassembly, modification of the product or alteration of the software codes;
- Failure to operate the equipment in accordance with the operating instructions and safety warnings present on the product or outlined in the document;

- Damage to the equipment caused by abnormal natural environment (force majeure, such as earthquake, fire, storm, flood, mudslide);
- Damage caused by the customer's failure to comply with transport and installation requirements;
- Damage caused by storage conditions not meeting the requirements specified in the product document;
- Damage to the hardware or data of the equipment due to customer negligence, improper operation or intentional damage;
- Damage to the system caused by third parties or customers, including relocation and installation of the system not in accordance with the requirements of this manual, and adjustment, modification, or removal of identification marks not in accordance with the requirements of this manual;
- Defects, failures or damage caused by acts, events, negligence or accidents beyond the reasonable control of the Seller, including power outages or electrical failures, theft, war, riots, civil commotion, terrorism, intentional or malicious damage, etc.

## General Requirements



The equipment operates at high voltages and improper handling poses a risk of electric shock or fire, which may cause death, serious injury, or substantial property damage. Always operate according to instructions:

- Follow the operating procedures and safety precautions described in this manual and other relevant document.
- Follow warning labels, cautions, and protective measures affixed to the equipment.
- Use the correct tools as specified in this manual and be proficient in the proper use of the tools.
- Comply with the safety regulations of the power plant, such as implementing the operation ticket and work ticket system.
- No one except the operator is allowed to access the equipment. Temporary warning signs or fencing must be erected to isolate the area during operation of the equipment.
- All warning labels, cautions, and protective measures affixed to the equipment shall remain legible. Unauthorized alteration, damage, or obstruction of such safety information is strictly prohibited. Any illegible markings shall be replaced in a timely manner.

- Do not perform installation, wiring, maintenance and replacement operations while the equipment is powered on.
- Do not clean the electrical components inside the equipment with water.
- Check the equipment for damage, such as holes, dents or other signs of possible internal damage.
- Check that the pre-installed cables of the equipment are securely connected.
- Check that the equipment is free from displacement of internal components, or unauthorized modification of internal structure and installation procedures.
- Do not power on the equipment until it has been installed or approved by qualified personnel.
- Measure the voltage at the contact point before touching any conductor surface or terminal, and confirm that the protective grounding conductor of the equipment or parts to be repaired is securely grounded to ensure that there is no risk of electric shock.
- Immediately press the EMERGENCY STOP switch and notify the on-site management if any liquid ingress is detected in the equipment.
- Do not open the cabinet door while the system is operating.
- For the first power - on of the equipment or when working in the live main - circuit area, it is recommended to wear level 1 arc - resistant clothing.

---

 **CAUTION**

- Do not perform arc welding, drilling, or cutting operations on the equipment. Such operations may damage the sealing of the entire enclosure, the electromagnetic shielding performance of the equipment, the internal components and cables, and the metal chips generated during the operation may cause short circuits, affecting the equipment function or causing equipment damage.
- The casing temperature is elevated during operation of the equipment, posing a risk of burns. Avoid physical contact with the equipment.
- If, during operation of the equipment, a fault is detected that may cause personal injury or damage to the equipment, stop operation immediately, notify the person in charge, and take effective protective measures.
- Evacuate the area immediately if an audible/visual fire alarm is activated.
- Close and lock the cabinet door if the equipment has to be left temporarily unattended during the maintenance procedure.

---

 **BEWARE**

- All transport, transit, installation, wiring, and maintenance activities must comply with the applicable laws, regulations, and standards of the country/region where the work is performed.
- The materials to be prepared by the user and the tools required during operation must comply with the applicable laws, regulations, and standards of the country or region where the work is performed.
- Permission from the local power authority must be obtained before the equipment is connected to the grid.
- Before opening the cabinet door during installation, operation, and maintenance, be sure to remove any accumulated water, snow, or other debris from the top of the enclosure to prevent debris from falling into the enclosure.

---

 **NOTE**

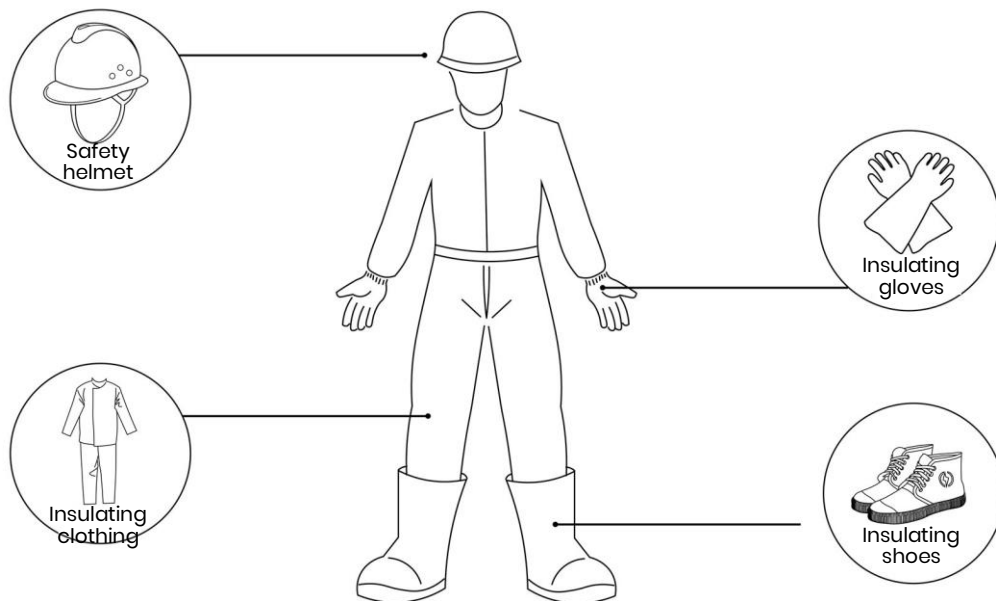
- It is prohibited to reverse engineer, decompile, disassemble, dismantle, adapt, implant, or perform other derivative operations on the equipment software. It is not allowed to research the internal implementation of the equipment, obtain the source code of the equipment software, or steal intellectual property rights in any way, nor is it allowed to disclose the results of any performance tests of the equipment software.
- It is recommended that users prepare video recording devices to document the detailed process of installation, operation, and maintenance of the equipment.

## 1.2 Personnel Requirements

- Only qualified personnel are permitted to perform tasks related to the equipment, including transport, transit, installation, wiring, and maintenance. When operating the equipment, operators must wear personal protective equipment that complies with local safety requirements.
- Operators must have completed Weiheng's relevant training programs, passed the required examinations, and demonstrated professional knowledge of the ESS.

### NOTE

Local regulations and industry standards shall be consulted for specific qualification requirements.



■ **Figure 1-1 Illustration of Personal Protective Equipment**

- Do not wear watches, bracelets, bangles, rings, necklaces, or other conductive items during installation, operation, or maintenance to prevent electric shock and burns.

- All transport, transit, installation, wiring, and maintenance activities must comply with the applicable laws, regulations, and standards of the country/region where the work is performed.
- It is important to ensure a comprehensive understanding of the construction and working principles of the entire ESS, and conduct all activities in accordance with the instructions provided in this manual.

# 1.3 Storage and Installation Environment Requirements

## General requirements

---

 NOTE

- During the storage period, relevant evidence demonstrating compliance with product storage requirements, including temperature and humidity logs, photos of the storage environment, and inspection reports, must be properly maintained.
- The storage environment must be maintained in a clean and dry condition to prevent dust and moisture contamination. The equipment shall be protected from exposure to rain or groundwater.
- The ambient air must not contain any corrosive or flammable gases.
- Do not store the equipment in a tilted or inverted position.
- Equipment that has been stored for two years or more should be inspected and tested by qualified personnel before being put into use.

## EES Storage Requirements

- Stacking storage is prohibited.
- Store the equipment on a level surface (for long-term or temporary storage).
- Keep the cabinet door securely closed.
- Storage temperature:  $-30\text{ }^{\circ}\text{C}\sim+60\text{ }^{\circ}\text{C}$ , humidity: 5%RH-95%RH.
- The energy storage system contains lithium battery packs and should be kept in a dry, well-ventilated area, protected from direct sunlight, rain, and sources of intense infrared radiation, organic solvents, corrosive gases, and ignition.
- The warehouse keeper should be responsible for monitoring the ESS inventory on a monthly basis and reporting it to the planning department on a regular basis, and should arrange for personnel to inspect the ESS that has been stored for an extended period in a timely manner.
- ESS must be shipped based on the "first in, first out" principle.

## Installation Environment Requirements

For site selection, please refer to **3.1 Site selection Requirements**. The following requirements must also be met during on-site installation:

- The installation layout of the ESS must meet the local standard requirements for fire protection distance or fire walls, including but not limited to the requirements of GB 51048-2014: Design Code for Electrochemical Energy Storage Power Station and NFPA 855 Standard for the Installation of Stationary Energy Storage Systems.
- It is prohibited to place the equipment in an environment with flammable, explosive gases, or smoke, and to operate the equipment in such an environment.
- The installation, use, and operation of outdoor equipment and cables (including but not limited to moving equipment, operating equipment and cables, plugging and unplugging outdoor signal interfaces, working at heights, and outdoor installation) is prohibited during thunderstorms, rain, snow, and winds of level 6 or above.
- It is recommended to install fences, walls, and other protective measures around the ESS, and erect safety warning signs to isolate the area and prevent unauthorized personnel from accessing the equipment during operation, which may result in personal injury or property damage.
- Do not block the vents and the cooling system during operation of the equipment to prevent fires caused by high temperatures.
- The equipment shall be installed in an area free from liquids and away from locations prone to condensation (such as under water pipes, air outlets) or prone to potential water leakage (such as under air conditioners, vents, machine room cable exit windows) to prevent liquid from entering the equipment and causing faults or short circuits.
- The installation site must be located away from sources of ignition, and no flammable or explosive materials shall be placed in the vicinity of the equipment.
- If the equipment is installed in an area with lush vegetation, periodic weeding and hardening of the soil beneath the equipment is required to prevent weed growth.

## Elevated Work Requirements

- Implement proper safety protection measures, including using safety helmets, safety harnesses, waist safety belts, and attaching them to robust and reliable structural members. Do not hang them on moving unstable objects or sharp-edged metals, to prevent the hook from slipping and causing a fall accident.
- The elevated work site must be clearly designated as a restricted, hazardous area with prominent markings to deter unauthorized access.
- The ground area directly beneath the elevated work zone must be kept clear of any stacked scaffolding, planks, or other debris. Ground personnel are prohibited from staying or passing directly below the high-altitude operation area.
- Do not throw objects from a high place to the ground or vice versa. All items must be transported using appropriate methods such as ropes, hanging baskets, overhead vehicles, or cranes.
- All scaffolding, planks, and work platforms utilized for elevated work must undergo a thorough safety inspection and certification prior to use, ensuring structural reliability and preventing scaffold overloading.
- Elevated work must be immediately suspended during rain or other potentially hazardous conditions. Thereafter, Weiheng's safety supervisor and relevant technicians must inspect all equipment and give approval before elevated work can be safely resumed.
- All edges and openings within the elevated work zone shall be outfitted with guardrails and markings to prevent the risks of accidental falls or step-through incidents.
- Securely carry all necessary apparatus and tools during operations to prevent accidental falls.
- If an elevated worker is found to be violating safety protocols and performing construction work improperly, the site supervisor or safety officer must immediately issue a warning and instruct the worker to make corrections. Work may not be resumed until the elevated worker is in full compliance with established operating specifications.

## 1.4 Loading/Unloading and Transport Requirements

---

### BEWARE

This product has been certified to comply with UN38.3 (UN38.3: Section 38.3 of the sixth Revised Edition of the Recommendations on the Transport of Dangerous Goods: Manual of Tests and Criteria) and SN/T 0370.2-2009 Rules for the Inspection of Packing for Export Dangerous Goods - Part 2: Performance Test, and is consequently classified as a Class 9 Dangerous Good.

Shipment conditions:

Energy storage battery cabinets must be inspected prior to shipment to ensure that the enclosure is intact and undamaged, the cabinet doors are properly closed and locked, no foreign objects are protruding from the interior, and no indications of smoke or burning are present. Failure to meet any of these criteria will result in the shipment being prohibited.

---

### NOTE

- The control cabinet must be inspected prior to shipment to ensure that the enclosure is intact and undamaged, the cabinet doors are properly closed and locked, no foreign objects are protruding from the interior, and no indications of smoke or burning are present. Otherwise, shipment is prohibited.
- During loading/unloading and transport, care should be taken to handle gently and provide moisture protection measures. Due to the influence of external environmental factors (such as temperature, transport and storage conditions), the product specifications are subject to the date of manufacture.
- The AC control cabinet is not intended for railway or air transport methods.
- For sea transport, the International Maritime Dangerous Goods Code (IMDG) must be observed.
- For land transport, the requirements of the Authorization Dangerous Road (ADR) or JT/T 617-2018: Regulations concerning Road Transportation of Dangerous Goods must be followed.
- Comply with the regulatory requirements set forth by the transport authorities in the countries of origin, transit, and destination.
- Comply with international transport rules for dangerous goods and the regulatory requirements set forth by the transport authorities in relevant countries.
- Monitoring is required throughout the entirety of the transport process.

- Vehicle used for land transport must have sufficient load capacity (DC-500kWh energy storage battery cabinet weight: approximately 5000 kg per unit).
- The speed limit for land transport is 80km/h on flat roads and 60km/h on rugged roads, with local traffic regulations taking precedence if they conflict with these guidelines.
- Stacking is prohibited during port handling and on-board transport. The following situations are strictly prohibited during transport: falling into water, dropping or mechanical impact, as well as inverting or overturning.

---

 NOTE

1. The energy storage battery cabinet falls or is mechanically impacted.
2. The energy storage battery cabinet is inverted or overturned.

If the above situation occurs, follow the emergency procedures in Section 1.8.

## 1.5 Electrical Safety

### Wiring Requirements

- Do not push cables directly off the vehicle or otherwise mishandle them.
- Do not route cables through the air inlet/outlet of the equipment.
- Cables of the same type shall be bundled together, while cables of different types shall be spaced at least 30 mm apart without intertwining or crossing.
- If the site has to be left unattended temporarily after or during the wiring process, the cable openings must be immediately sealed using sealing mud to prevent the ingress of small animals.
- Cables used in high-temperature environments are susceptible to insulation aging and damage. A minimum clearance of 30 mm must be maintained between cables and heat-generating components or heat source peripheries.
- Select cables that are in compliance with local laws and regulations.
- Cable troughs and openings must be free of sharp edges and provided with appropriate protection.
- Cable conduits or openings shall be protected against damage from sharp edges or burrs.
- Cables used in the ESS must be firmly connected, well-insulated, and comply with the appropriate specifications.
- After wiring, the cables must be securely fixed using cable supports and clamps. For cables in backfilled soil areas, ensure they are in close contact with the ground to prevent deformation or damage during backfilling.
- At low temperatures, violent impact and vibration may cause the outer plastic sheath of the cables to become brittle and crack. To ensure construction safety, the following requirements shall be followed:
  - ✧ All cables must be laid and installed at temperatures above 0°C. Care should be taken when handling cables, especially in low-temperature environments.
  - ✧ If cables are stored at temperatures below 0°C, they must be placed at room temperature for at least 24 h prior to installation.

## Grounding Requirements

- Do not damage grounding conductors.
- Do not operate the equipment without installed grounding conductors.
- For equipment requiring grounding, always install the protective ground wire first and remove it last.
- The main grounding body of the equipment must be permanently connected to the protective grounding network. Before operating the equipment, the electrical connection must be checked to ensure reliable grounding.
- The grounding impedance of the equipment shall meet the requirements specified in GB 50054 and any applicable local electrical standards

## AC/DC Operation Requirements

- Before installing or removing the power cord, turn off the power switch first.
- Prior to connecting the power cord, verify that the label on the power cord is correct.
- If the equipment has multiple inputs, all inputs shall be disconnected and the equipment shall be completely de-energized before any work is performed.

## Operation, Maintenance and Repair Safety Requirements

1. Turn off the circuit breaker before connecting or disconnecting any cables.
2. Place a "Do Not Close" warning sign on the open switch.
3. Use a voltage tester of the appropriate rating to verify the equipment is completely de-energized.
4. Cover or wrap any nearby live parts with insulating sheeting or tape.
5. Before performing any operation, maintenance or repair activities, connect the circuit to be repaired securely to the grounding circuit using a grounding wire.



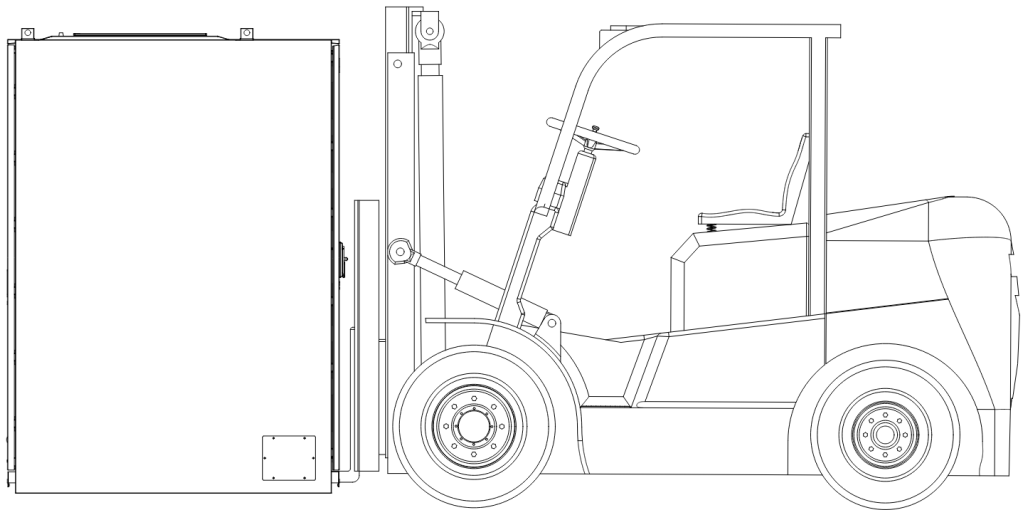
- Prior to connecting cables, verify that the label on the cable is correct.
  - If the equipment has multiple inputs, all inputs shall be disconnected and the equipment shall be completely de-energized before any work is performed.
- 
6. After the repair is completed, remove the grounding wire between the repaired circuit and the grounding circuit.

## 1.6 Mechanical Safety

### Transport Safety

**i BEWARE**

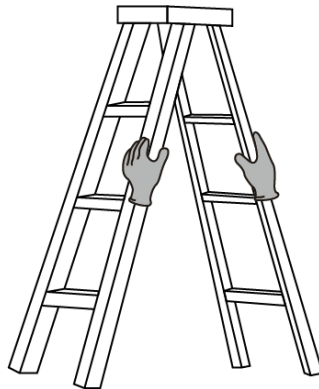
- This equipment must be lifted using a lifting frame.
- When using a forklift to move the equipment, ensure that the forklift has sufficient load capacity and that the center of gravity of the equipment is between the forklift legs to prevent personal injury and equipment damage;
- Forklift load capacity:  $\geq 6$  t;
- Recommended fork length:  $\geq 1.8$  m, fork width: 140cm~160cm, fork thickness: 25 mm~70 mm.



■ **Figure 1-2 Forklift Transport**

## Safety Instructions for Ladder Use

- Using straight ladders is prohibited.
- Before using a ladder, ensure it is in good condition and the load capacity meets the requirements. Overloading is strictly prohibited.
- Use wooden or fiberglass ladders when working overhead where electricity may be involved.
- When working overhead, it is preferable to use platform ladders with guardrails, where all four feet are securely fixed and the ladder is held by one person.



■ **Figure 1-3 Holding Ladder**

- For herringbone ladders, the rope must be secured and a person must hold the ladder during use.
- When climbing a ladder, please pay attention to the following actions to reduce danger and ensure safety.

---

**CAUTION**

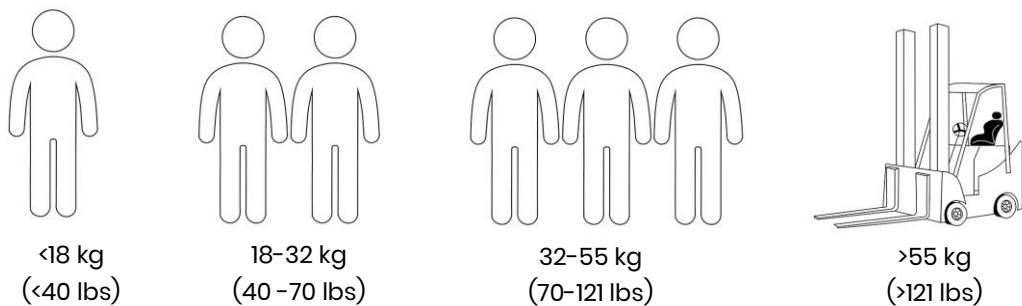
- Maintain a stable body posture.
- Stand on the ladder without exceeding the 4th rung from the top.
- Ensure your center of gravity remains within the ladder frame.

## Equipment Exterior Drilling Safety

- Before drilling, carefully select the drilling location to avoid short circuits or other adverse effects.
- Wear safety goggles, gloves and other personal protective equipment when drilling.
- Effectively shield the equipment during drilling to prevent ingress of debris, and clean and remove debris promptly afterward.

## Safety Instructions for Handling Heavy Objects

- When handling heavy objects, arrange for the number of people recommended in the diagram to ensure collaborative operation and load sharing.



### ■ Figure 1-4 Installation Personnel Requirements

- Wear protective gloves, anti-smash anti-puncture safety shoes and other personal protective equipment when handling the equipment by hand.
- Protect the equipment from surface scratches or damage to internal components/cables during handling.
- For forklift handling, ensure the forks are centered under the load to prevent tipping. Secure the equipment to the forklift with ropes before moving, and assign a dedicated person to monitor during movement.
- Move the equipment carefully to avoid collisions or falls.

## 1.7 Battery Safety

### Declaration

Weiheng will not be liable for damage to the battery supplied by Weiheng due to the following reasons:

- Battery capacity loss or irreversible damage caused by the customer's failure to charge the battery in a timely manner, resulting in expired storage.
- Damage to the battery caused by the customer's failure to accept the battery in a timely manner;
- Failure by the customer to properly set the system operation and management strategy, resulting in battery performance degradation;
- Unauthorized changes to the battery pack application scenario by the customer or a third party without prior notification to Weiheng, such as unauthorized connection of additional loads to the battery pack, and mixing the original battery pack with others, including different brands or varying rated capacities;
- Damage to the battery pack caused by the equipment operating environment or external power parameters failing to meet the normal operating requirements, including excessively high or low actual temperatures;
- Improper maintenance by the customer resulting in frequent over-discharge of the battery, capacity extension on site by the customer or long-term inability to fully charge the battery, etc.
- Failure by the customer to properly maintain the battery in accordance with the supplied equipment operating manual, including but not limited to ensuring the integrity of the cooling system, and addressing any loose or damaged HV cable harness or loose or missing structural fixing bolts;
- Theft of battery packs;
- Battery packs beyond the warranty period.

### Basic Requirements



- Do not expose the battery pack to high temperatures or near heating devices, such as direct sunlight, fire sources, transformers, heaters, etc. Overheating of the battery pack may cause fire or explosion hazards.

- Do not disassemble, modify, or damage the battery pack in any way (e.g. by inserting foreign objects, immersing in water or other liquids) to prevent battery pack leakage, overheating, fire or explosion.
- Lithium-ion battery energy storage systems pose a high risk of fire. Before performing any battery-related operations, it is essential to thoroughly consider the following safety risks:
  1. The electrolyte in the battery pack is flammable, toxic, and volatile.
  2. Thermal runaway of the battery pack may generate flammable and harmful gases such as carbon monoxide and hydrogen fluoride.
  3. The accumulation of flammable gases from thermal runaway of the battery pack poses a risk of combustion and explosion.
- The battery pack shall be stored with its original outer packaging in a dedicated warehouse, separated from other materials. Outdoor storage is prohibited. The stacking height must be maintained within safe limits. Fire fighting facilities, such as fire sand and fire extinguishers, must be provided on site in accordance with regulations.
- For outdoor applications, it is recommended to charge an unpacked battery pack within 24 h. If timely charging is not possible, the battery pack shall be stored in a dry, indoor environment free of non-corrosive gases.
- Under normal circumstances, do not remove the outer packaging of the battery pack. Recharging, if necessary, must be performed by qualified personnel as per the specified requirements. The battery pack must be properly repackaged upon completion of recharging.
- The battery pack shall be properly oriented according to the anti-inversion label or marking on the packaging to prevent cell leakage from prolonged inverted storage.
- The ESS shall be subject to regular fire safety inspections, at least once a month.
- Use the battery pack only within the temperature range specified in this manual. Do not charge the battery pack when the ambient temperature is below the lower operating limit to prevent crystallization and internal short circuits.
- The battery pack must be protected from impacts.
- The storage location for damaged battery packs must be free of flammable materials, with access restricted to unauthorized personnel. During storage, damaged battery packs shall be monitored for signs of smoke, flames, electrolyte leakage, or heating.
- The battery pack that has been accidentally exposed to water must not be installed, but must be transported to a safe, isolated location for timely replacement with spare parts.

- The storage area must be protected from direct sunlight and rain, and must be dry, well ventilated, clean, and free from excessive infrared/ionizing radiation, organic solvents, and corrosive gases.
- Dispose of used battery packs in accordance with local laws and regulations. Do not treat them as household waste to prevent environmental contamination.
- Do not use damaged battery packs (such as dents or other damage on the casing), as damaged battery packs may release flammable gases and shall not be stored near undamaged products.

## Recharging Requirements

Weiheng will not be liable for damage to the battery supplied by Weiheng due to the following reasons:

- Recharging is mandatory if the battery cabinet has not been charged for more than 5 months. Failure to adhere to the recharging schedule may compromise the performance and lifetime of the battery cabinet.
- The production completion date of the battery cabinet can be determined by querying the shipment records using the battery cabinet serial number (SN) or by consulting Weiheng's service engineers.

## Battery Pack Installation Requirements



Before installing the battery pack, check it for abnormalities. Battery pack abnormalities include the following:

- The battery pack casing exhibits visible deformation or damage;
- The total voltage between the positive and negative terminals of the battery pack is significantly lower than the specified range.
- Use only the specified battery pack model. Use of non-specified models may result in damage to the battery cabinet.
- Before installing the battery pack, check whether the packaging is intact. Battery packs with damaged packaging must not be used.
- The battery pack must be placed horizontally and secured.
- Do not place any installation tools or debris on the battery pack during installation.
- When installing the battery pack, it is important to properly connect the positive and negative terminals. Short-circuiting the positive and negative terminals of the battery pack is strictly prohibited.
- When installing the battery pack, use a torque wrench to ensure that the terminals are tightened securely. Check the terminals on a regular basis for signs of loosening.

---

## Battery Pack Short-Circuit Protection



A short circuit in the battery pack may generate a large current surge and release significant energy, posing a serious risk of personal injury and property damage.

- 
- When installing and maintaining the battery pack, use insulating tape to wrap the exposed wire terminals on the battery pack.
  - Prevent foreign objects (such as conductive objects, screws, liquids) from entering the battery pack and causing short circuits.

## Hazard and Toxicity Information



- Hazard: A damaged battery pack may cause overheating or electrolyte leakage. Electrolyte is flammable. If leakage occurs, immediately move the battery cabinet away from any heat source.
- Toxicity: Vapors from a burning battery pack may cause irritation to the eyes, skin, and throat.

---

## Countermeasures for Abnormal Battery Packs



- In case of electrolyte leakage or an unusual odor, avoid contact with the leaking liquid or gas. Access shall be restricted to unauthorized personnel. Contact qualified personnel immediately for proper handling. Professionals must wear personal protective equipment, including goggles, rubber gloves, a gas mask, and protective clothing to protect against possible hazards caused by electrolyte spillage.
- Electrolyte is corrosive and may cause skin irritation and chemical burns. In case of exposure to electrolyte, the following measures must be taken:

- **Inhalation:** Evacuate the contaminated area, provide fresh air, and seek medical attention immediately.
  - **Eye contact:** Immediately flush eyes with plenty of water for at least 15 min, without rubbing the eyes, and seek medical attention.
  - **Skin contact:** Immediately wash the affected area with soap and water, and seek medical attention.
  - **Ingestion:** Seek medical attention immediately.
- 

## Battery Pack Drop Incident

- If the battery pack falls (with or without packaging) but shows no visible deformation or damage, and no noticeable odor, smoke, or fire, proceed with caution and safety in mind as follows:
  - Warehouse: Evacuate personnel, use mechanical tools to transfer the battery pack to a safe, open area by qualified personnel, and contact Weiheng's service engineers. Allow the battery pack to rest for 1 h and monitor the temperature to ensure it remains within ambient temperature  $\pm 10^{\circ}\text{C}$  before further proceeding.
  - ESS site: Evacuate personnel, close the ESS door, use mechanical tools to transfer the battery pack to a safe, open area by qualified personnel, and contact Weiheng's service engineers. Allow the battery pack to rest for 1 h before further proceeding.
- If the battery pack exhibits a noticeable odor, damage, smoke, or fire after a drop, immediately evacuate personnel, contact professionals, and promptly call emergency services. Professionals should use firefighting equipment to extinguish the fire while ensuring safety.
- Do not continue to use a dropped battery pack. Contact Weiheng's service engineers for evaluation.

## 1.8 Maintenance

---

 **CAUTION**

Before removing any component from the cabinet, verify that all other components are securely fastened.

---

- A minimum of two people is required on site during ESS maintenance.
- During equipment maintenance, always use insulating materials to cover nearby live components.
- Do not open the cabinet door in severe weather conditions such as rain, snow, lightning, sandstorms, or heavy fog.
- Never allow objects (such as fingers, components, screws, or tools) to come into contact with a running fan before it is powered off or stops rotating.
- Do not power on the equipment before troubleshooting.
- During live system patrol inspections, observe hazard warnings on the equipment and avoid standing near the cabinet door.
- After shutting down the equipment other than the battery packs, wait 15 min to ensure complete de-energization before proceeding with any operation on the equipment.
- A "Do Not Close" warning sign must be displayed on any switch that is disconnected for maintenance.
- After replacing power components or changing wiring in the ESS, manually initiate wiring detection and topology identification to prevent system malfunctions.
- Lock the cabinet door, secure the safety cable, and keep the key in a safe location immediately after completing maintenance and replacement.

## 1.9 Emergency Procedures

In the event of an incident, including but not limited to those listed below, immediately take appropriate measures to ensure the safety of all personnel on site, and contact Weiheng's service engineers.

### In Case of Fire

---



Recommendations for on-site operation and maintenance personnel:

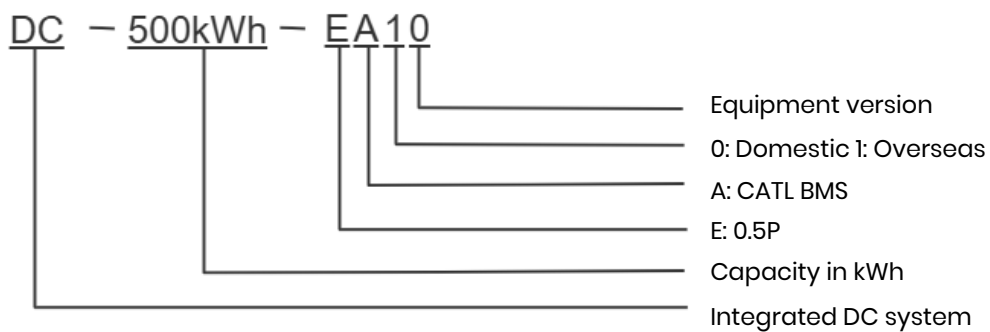
1. In case of fire, evacuate the building or equipment area and activate the fire alarm bell. Call the fire department and provide them with relevant product information, including but not limited to battery pack type, ESS capacity, and battery pack distribution.
2. Never re-enter the burning building or equipment area, or open the ESS door. Isolate and monitor the site, and restrict access to unauthorized personnel.
3. After contacting the fire department, remotely shut down the system while prioritizing your own safety.
4. Upon the arrival of professional firefighters, provide them with relevant product information, including but not limited to battery pack type, ESS capacity, battery pack distribution, and user manual.
5. Once professional firefighters confirm the fire is extinguished, allow qualified personnel to handle the situation according to local regulations. Do not open the ESS door without authorization.
6. Post-disaster product maintenance: Contact Weiheng's service engineers for evaluation.

Recommendations for fire professionals:

1. Review the product information provided by operation and maintenance personnel, including but not limited to battery pack type, ESS capacity, battery pack distribution, and the user manual.
  2. Do not open the ESS door if the internal safety of the system cannot be guaranteed.
  3. Please follow local fire regulations for fire extinguishing operations.
-

# 2 Product Introduction

## 2.1 Model Description



Product Model Description:

This document primarily focuses on the following product models:

DC - 500kWh - EA10

## 2.2 Functions and Features

### Function

1. Energy Storage and Expansion Capacity
  - o Single cabinet capacity: The standard cabinet is designed with a capacity of 509kWh and equipped with CATL high-energy-density LFP cells, supporting continuous charging and discharging at 0.5P rate.
  - o Multiple cabinets in parallel: A maximum of 2 cabinets can be connected in parallel, allowing total system capacity to expand to 1018 kWh. Cluster management is enabled via CAN/RS485 communication protocol, with no additional controller required for expansion.
2. Intelligent Liquid Cooling Temperature Control System
  - o Partitioned precise temperature control: Temperature sensors are configured in the cabinet and linked to the independent air-cooling system, and the air volume is dynamically regulated to maintain the working temperature of the battery cell within 15~35°C.

### 3. Five-level Safety Protection System

- o Active pressure relief for thermal runaway: The enclosure is equipped with explosion vent panels on the top, allowing for directional venting (pressure relief response time  $< 5$  ms; venting pressure threshold  $\leq 20$  kPa).
- o Triple fire detection: Built-in smoke sensor (sensitivity 0.1 dB/m), temperature sensor (accuracy  $\pm 0.5^{\circ}\text{C}$ ), and combustible gas detector (detection range 0-1000 ppm) are integrated to facilitate comprehensive millisecond-level multi-signal assessment.
- o Aerosol fire extinguishing in seconds: Perfluorohexane aerosol can be released within 20 s after activation, achieving an extinguishing concentration of  $\geq 6\%$  and leaving no corrosive residue.

### 4. Modular Maintenance Design

- o Pack-level module replacement: The cabinet integrates 10 independent CATL battery pack modules, allowing for quick replacement of defective modules.
- o Health status visualization: The EMS displays real-time SOC, SOH, and temperature curves for each pack, enabling quick assessment of pack health.

## Features

### 1. High-safety Explosion-roof Structure

- o the explosion vent panels on the top of the enclosure allow for directional venting without damaging surrounding equipment. The enclosure is designed with a hot-dip galvanized steel tube framework for enhanced impact strength.

### 2. Fire Safety Compliance

- o the aerosol fire extinguishing system is certified according to GB/T 34031-2023, and the smoke and temperature detectors comply with EN54, ensuring compatibility with industrial fire linkage requirements.

### 3. Flexible Deployment

- o Single cabinet dimensions (W×D×H): 1940 mm × 1500 mm × 2100 mm, allowing for outdoor side-by-side installation with only 100 mm spacing between cabinets to minimize footprint requirements.

### 4. Intelligent Interconnection

- o It supports Modbus TCP and IEC 61850 protocols, enabling connectivity to energy management platforms for multi-cabinet SOC balancing, remote charge/discharge strategy switching, and error warning.

## 2.3. Appearance

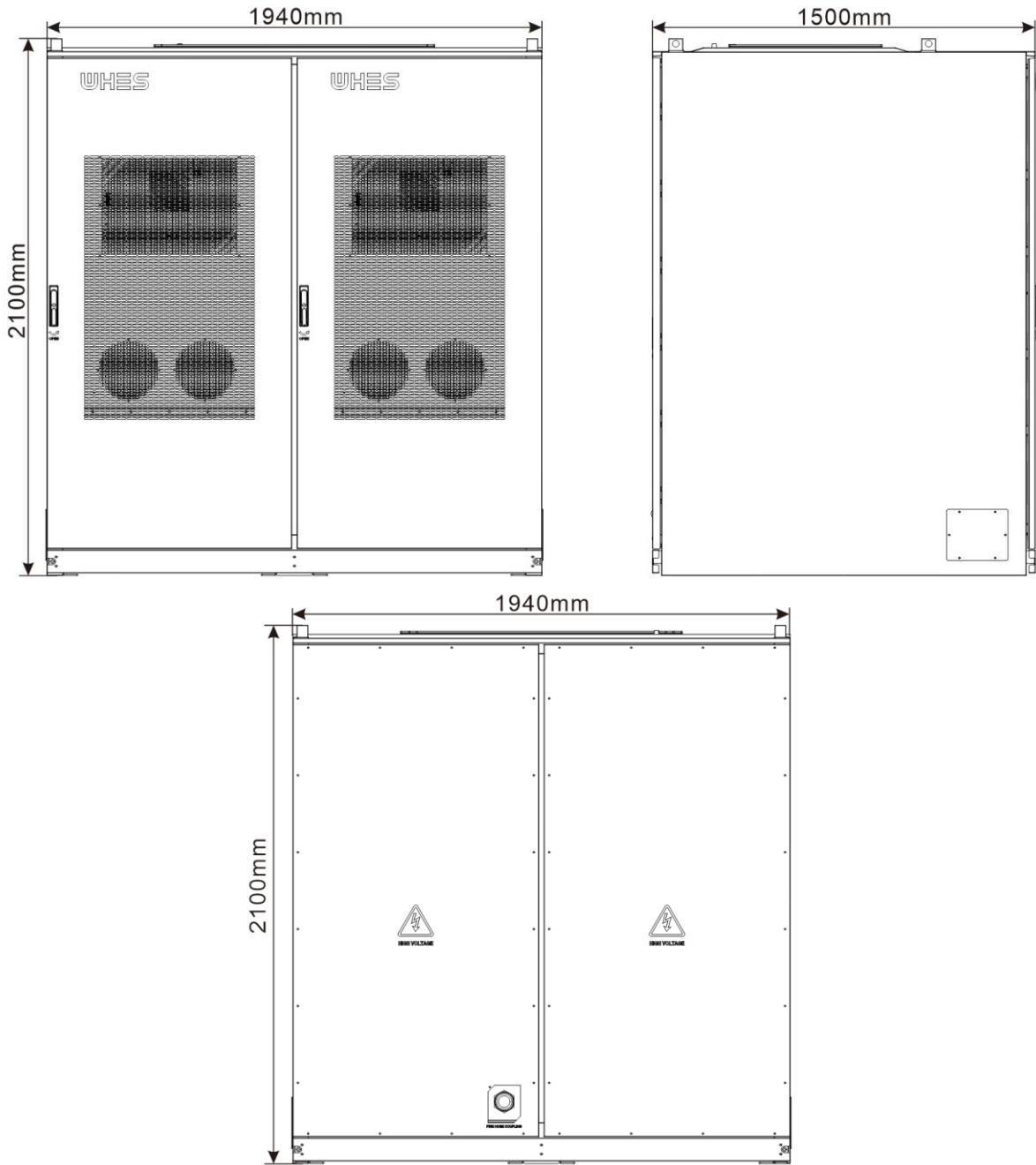
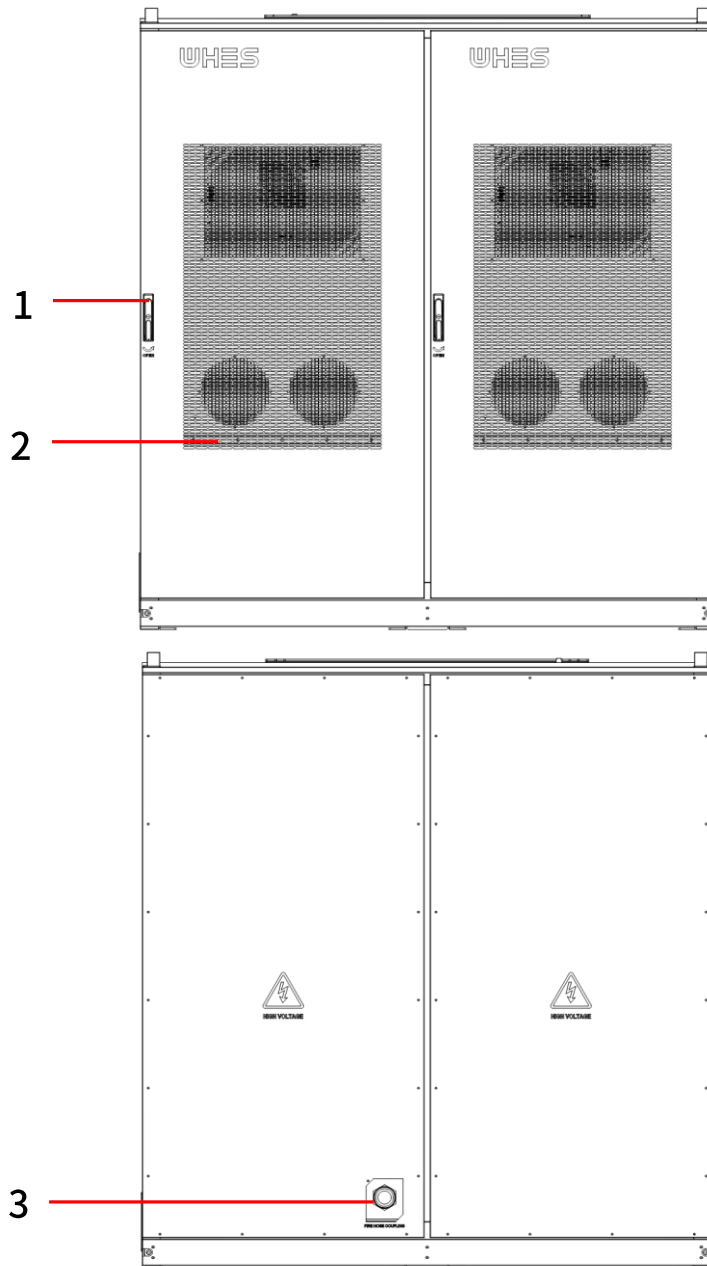


Figure 2-1 Appearance and Dimensions

**NOTE**

The foundation must be provided according to the construction site design drawings, which can be obtained from Weiheng's product manager.

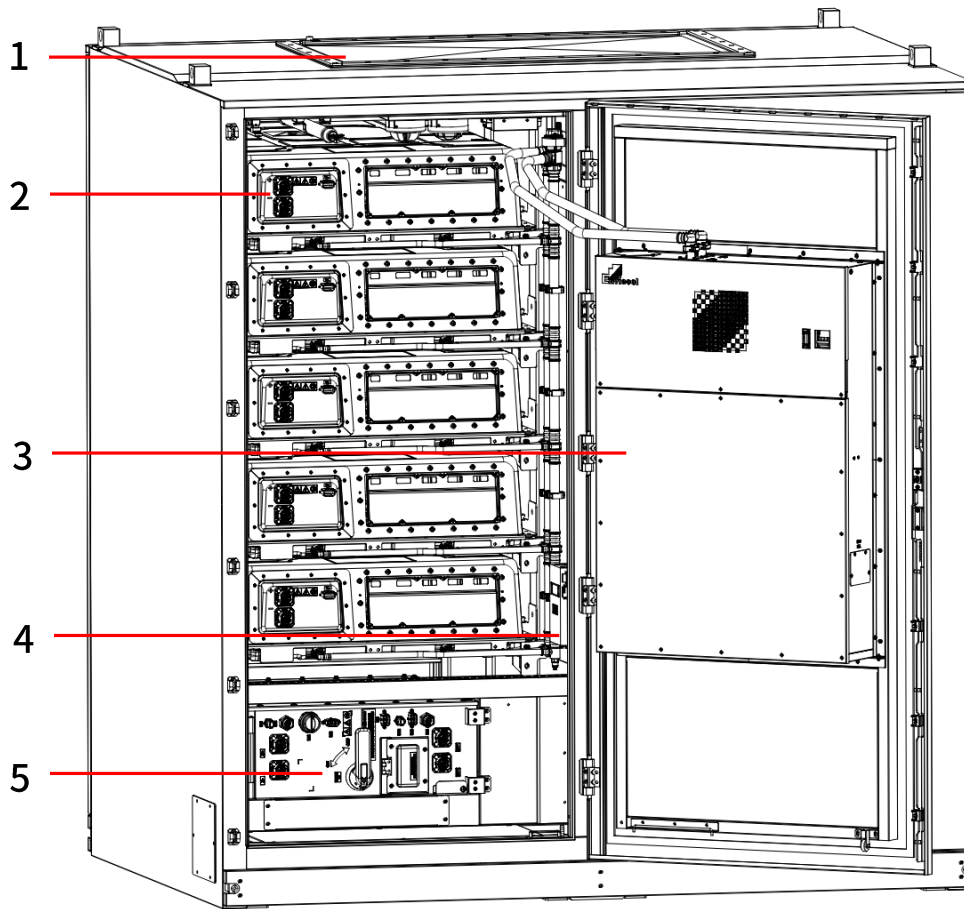
## 2.4 Components



■ Figure 2-2 Battery Cabinet - Front and rear views

**Table 2-1** Component Configuration

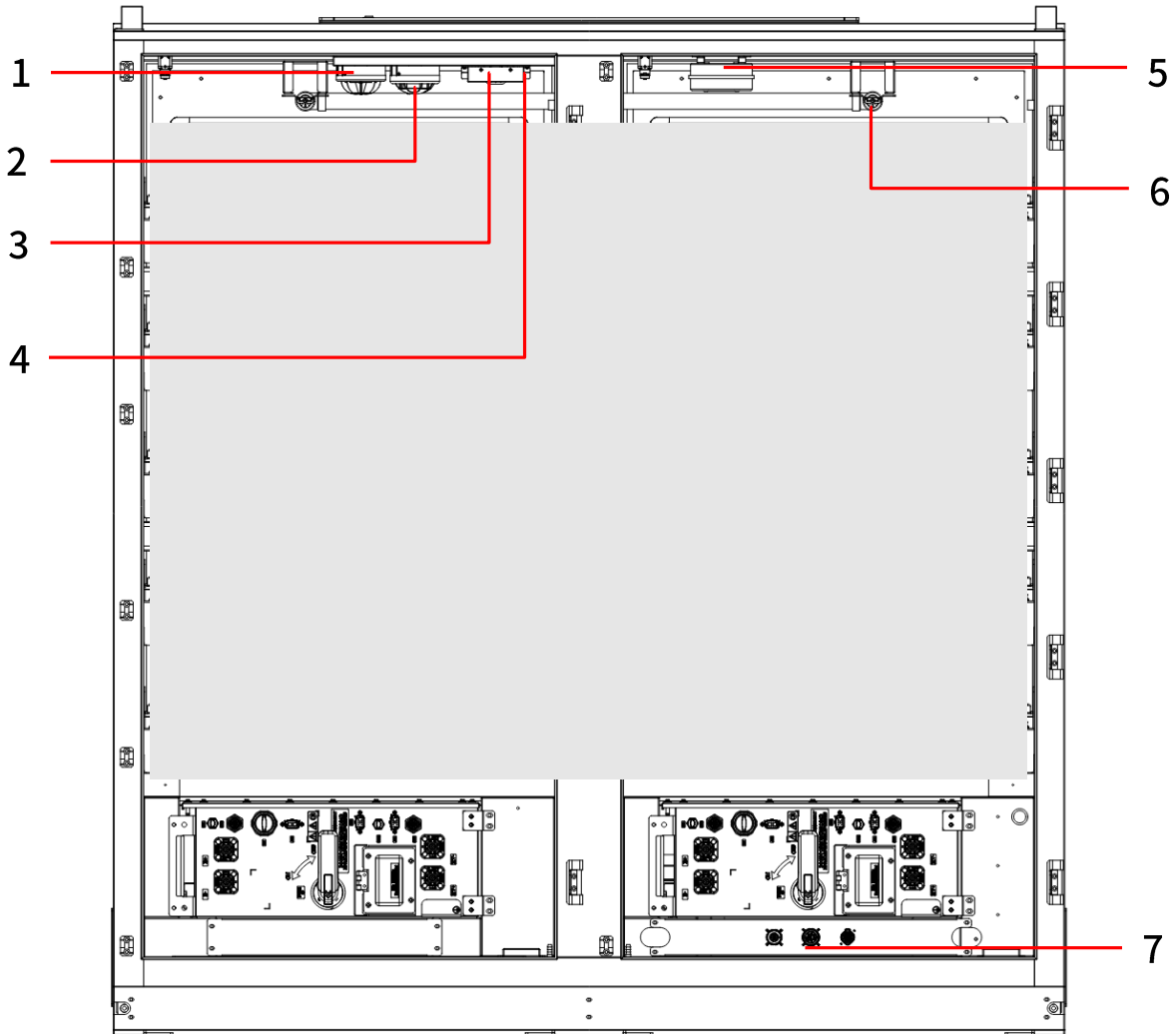
No.	Name	Quantity	Description
1	Door lock	1	Turn the handle to open the control cabinet door.
2	Thermovent	2	Wind inlets and outlets
3	Water spray connection	1	Install the DN65 threaded adapter for assembly



■ **Figure 2-3 Battery Cabinet - Interior -1**

**Table 2-2** Component Configuration

No.	Name	Quantity	Description
1	Explosion Vent Panel (Optional)	1	Directional venting to quickly release internal pressure, and ensure cabinet safety.
2	Battery Pack	10	Modular cell design to ensure safety, efficiency, and ease of maintenance.
3	Liquid Cooling Unit	2	Make sure that the temperature of the battery cells remains within the range of 15 to 26 degrees Celsius to ensure their stable operation.
4	Dehumidifier	2	Reduce humidity to prevent the ESS from moisture damage.
5	HV Box	2	Intelligent electrical isolation monitoring to enable safe and efficient power distribution.



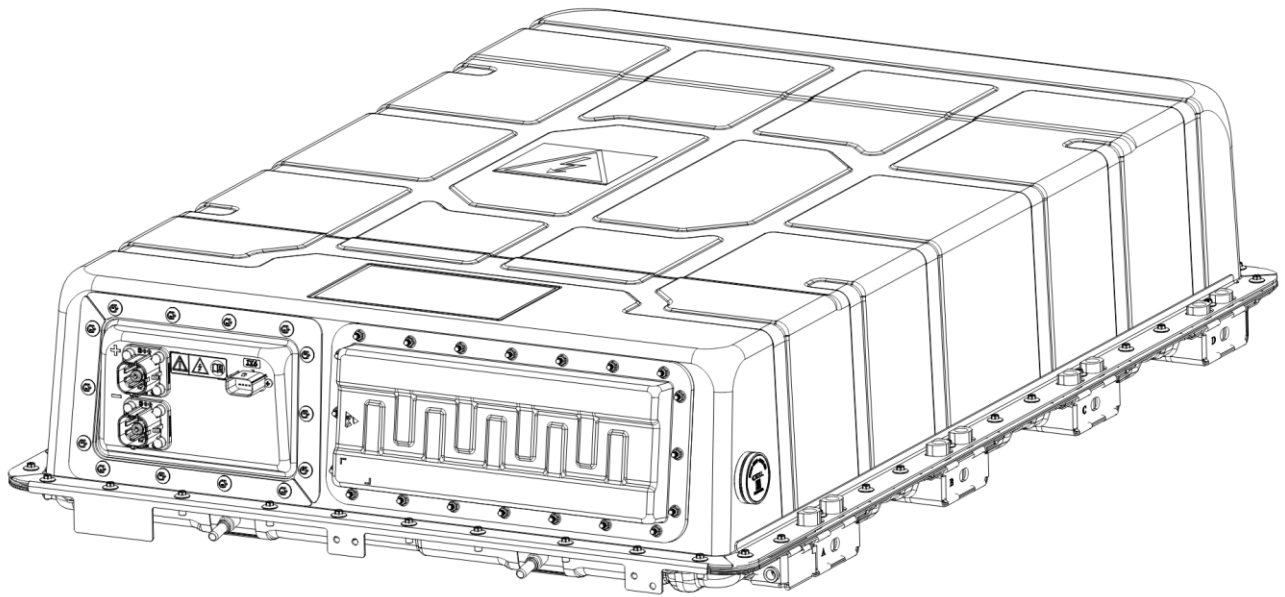
■ **Figure 2-4 Battery Cabinet - Interior -2**

**Table 2-3** Component Configuration

No.	Module Description	Quantity	Description
1	Temperature Heat Detector	1	Real-time internal temperature detection to trigger safety alarms.
2	Smoke Detector	1	Real-time smoke detection to trigger safety alarms.
3	Gas Detector Module	1	Real-time acquisition of gas sensor data.
4	Gas Interface Module	1	Real-time detection of hazardous gases to trigger safety alarms.
5	Condensed Aerosol	1	Aerosol fire extinguishing in seconds to suppress re-ignition without residue, and ensure cabinet safety.
6	Water Spraying Connection	2	DNI15 external thread connector.

7	Communication Terminal Block	3	<p>CZ1: Battery cabinet water cooling, HV box power supply.</p> <p>CZ2: Battery cabinet auxiliary power supply, dehumidifier power supply, etc.</p> <p>CZ3: Communication with the battery cabinet.</p>
---	------------------------------	---	---

### 2.4.1 Battery Pack



■ **Figure 2-5 Battery Pack Appearance**

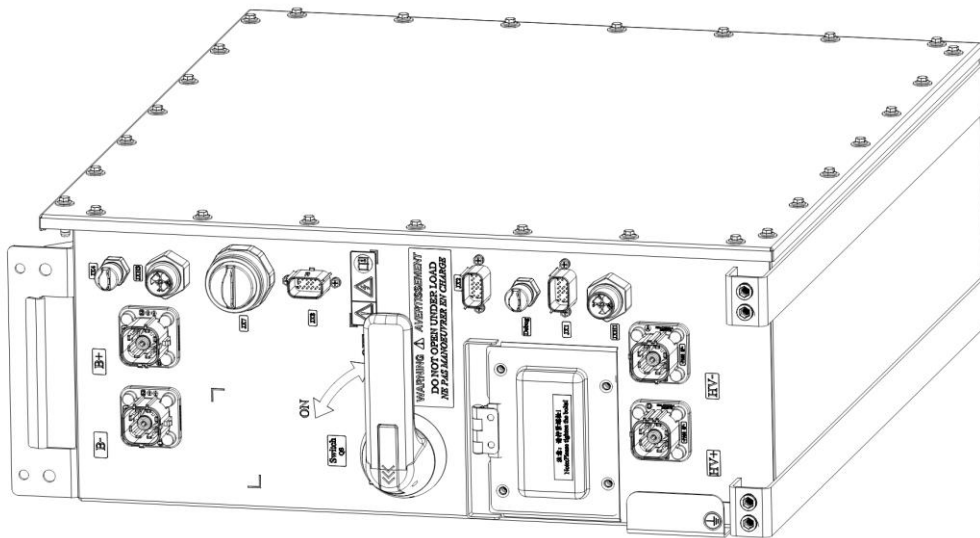
**Module Description:** This battery pack consists of 52 306Ah batteries connected in series (1P52S configuration). Equipped with a liquid cooling system and IP67 protection grade, it can operate effectively in high-altitude areas. It is highly suitable for high-reliability energy storage applications, featuring high efficiency and durability, and is applicable to harsh environments.

**Table 2-4** Technical Parameters

Project	Specification
Rated Capacity	50.918kWh
dimension voltage	166.4VDC
Voltage range	130~189.8VDC
Rated Charging Current	153A
Maximum Charging Current	195.9A (<1 min)
Rated Charging Power	25.459kW
Rated Discharge Current	153A
Maximum Discharge Current	195.9A (<1 min)
Rated Discharge Power	25.459kW

Auxiliary power supply	24VDC
Protocol	CAN2.0
Dimensions	242±5mm(H)810±5mm(W)1150±5mm(D)
Weight	325±10kg
IP rating	IP67
cooling method	Liquid cooling
Battery Certification Standards	UL9540A, UN38.3, UL1973, IEC62619, RoHS, Reach

## 2.4.2 HV Box

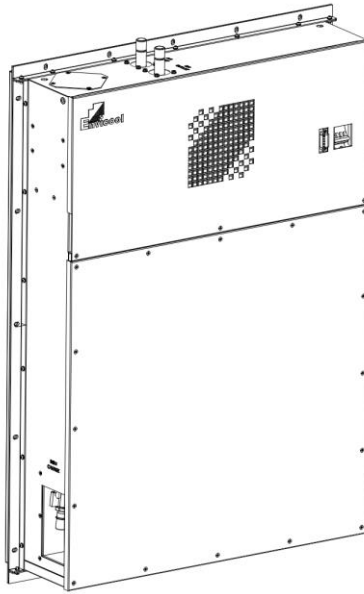


■ **Figure 2-6 HV Box Appearance**

**Module Description:** The HV control box serves as an intermediate unit connecting battery clusters and energy storage converters, providing functions such as battery cluster voltage/current monitoring, circuit breaker control, and detection protection. Its design comprehensively considers the electrical characteristics, thermal management performance, operational reliability, safety protection, and maintainability of all internal components. Through optimized layout, it achieves the design goals of compact structure, flexible configuration, and reliable safety. The mounting ears of the box are coated with conductive paint to ensure electrical connectivity with the cluster frame.

The interior integrates key electrical components such as the battery cluster management module (SBMU), power module, and other critical elements. The built-in BMS master control module is equipped with a CAN (Controller Area Network) communication bus interface, supporting the functional requirements of the secondary BMS architecture in energy storage systems. This enables control protection, status monitoring, and data communication functions for energy storage battery clusters.

### 2.4.3 Chiller



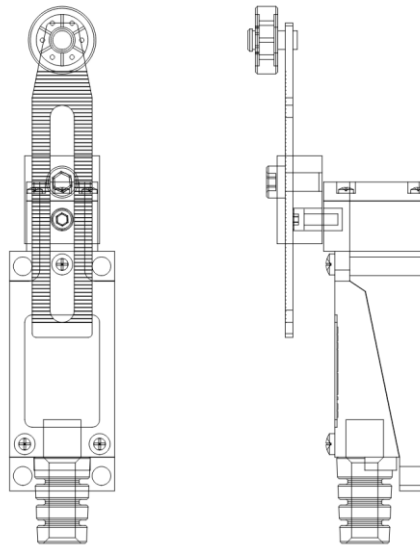
■ **Figure 2-7 Chiller Appearance**

**Module Description:** The chiller features a compact door-mounted design. It delivers robust performance with integrated cooling and heating functions, and is compatible with RS485/CAN communication protocols for easy system integration. It complies with RoHS standards, offers low energy consumption and high stability, making it suitable for high-reliability applications such as industrial cooling and outdoor temperature regulation, while ensuring energy efficiency and long-term operational performance.

Table 2-5 Technical Parameters

Project	Specification
External Dimensions	1000×700×220mm
Installation method	Door-mounted
IP Protection Rating	IPX5
Refrigerant	R134a
Coolant	50% ethylene glycol-water solution
RoHS Certification	Yes
Air Outlet	Front outlet
Cooling Capacity @L45/W18	5.0kW
Heating Capacity @Tu=10°C	2.5kW
Maximum Power Consumption	2.8kW
dimension voltage	220~240V 50/60Hz
Max operating current	15.8A

## 2.4.4 Travel Switch



■ **Figure 2-8 Travel Switch Appearance**

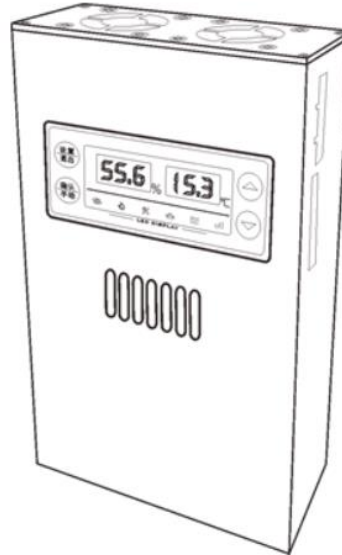
**Component Description:** This travel switch is designed to control the travel of motion mechanisms, and change the direction or speed of movement, and can be used in applications such as automatic control of machine tools, position limiting of motion mechanisms, and travel or program control.

**Table 2-6** Technical Parameters

Model	CHNT/YBLX-ME/8108
Protection Rating	IP62
Operation Frequency	20 cycles/min
Relative humidity	When the maximum temperature is +40°C, the relative humidity of the air shall not exceed 50%. Higher relative humidity is allowed at lower temperatures, for example, up to 90% humidity at 20°C.
dimension voltage	AC-15:380V DC-13:220V
Rated Operating Current	AC-15:0.8A DC-13:0.16A
Installation Category	II
Pollution Level	Level 3
Rated Insulation Voltage	415V
Rated Impulse Withstand Voltage	2.5kV
Altitude	≤2000m

Installation Conditions	To be installed in a place without significant shaking, impact or vibration
-------------------------	---

### 2.4.5 Dehumidifier



■ **Figure 2-9 Dehumidifier Appearance**

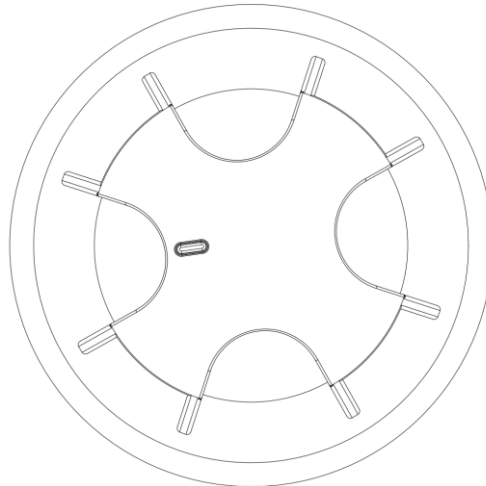
**Component Description:** The dehumidifier has the following features: compact, lightweight, easy and quick to install; switchable automatic and manual dehumidification modes, adjustable temperature and dehumidification activation values; active condensation of dehumidification air duct, heated dehumidification of exhaust gas, effectively achieving comprehensive control of moisture prevention and dehumidification in the closed space of electrical cabinets.

**Table 2-7** Technical Parameters

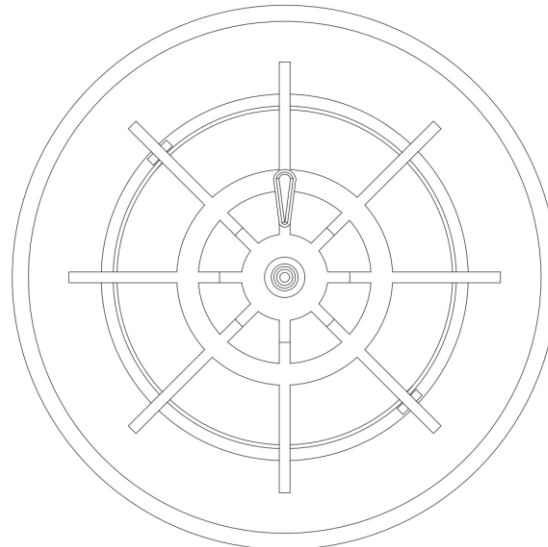
Model		JY-760A	
Power Supply	AC220V	Dehumidification Efficiency	380 mL±5%/24 h (@60W 35°C RH=85%)
Heating Power	50 ~ 300W	Dehumidification Temperature	5°C ~ 45°C
Power Selection	20W~60W	Working temperature	-25°C ~ 75°C
Humidity Detection Range	20%RH~98%RH	Temperature Detection Range	-20°C ~ 85°C
Dehumidification Activation Value	25%RH~98%RH	Temperature Activation Value	1°C ~ 55°C
Humidity Measurement Accuracy	±3%RH	Temperature Measurement Accuracy	±1°C
Display Mode	6-digit	Display Resolution	0.1

Casing Material	Aluminum alloy	External Dimensions	180×62×110mm (W*D*H)
Net weight	1kg	Drainage Pipe	Silicone D10mm

## 2.4.6 Fire Alarm Device



■ **Figure 2-10 Smoke Detector**



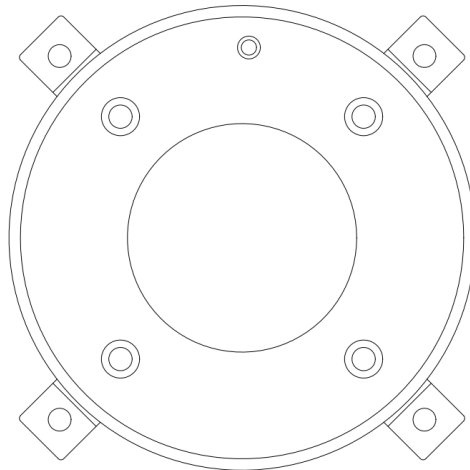
■ **Figure 2-11 Temperature Heat Detector**

**Component Description:** The smoke and Heat detectors in the energy storage cabinet are designed to monitor environmental smoke and temperature changes in real time and identify abnormal conditions based on dual signals. It supports remote alarm signal output and integration with the fire protection system, ensuring the safe operation of the battery module within the cabinet and enhancing the overall protection and reliability of the ESS.

**Table 2-8** Technical Parameters

No.	Model/Spec	Value
1	Operation voltage	24V DC (16V ~ 28V)
2	Standby current	≤60μA
3	Alarm Current	10mA ~ 30mA
4	Indicator light status	The red-light flashes during normal operation and remains steady when an alarm is triggered.
5	Explosion protection mark	Exib II CT6 Gb
6	Explosion-proof Certification No.	CE12.2146 (temperature detector) / CE11.2130 (smoke detector)
7	Safety Parameters	$U_0=28V$ , $I_0=93mA$ (temperature detector: $C_0=0.083\mu F$ , $L_0=4mH$ )
8	Alarm Reset Method	Instantaneous power cutoff (min. 5 s, voltage ≤ 2.5 V DC)
9	Operating temperature range	Temperature detector: -10°C ~ +50°C (AIR), -10°C ~ +65°C (BS) Smoke detector: -10°C ~ +55°C
10	Relative humidity	≤95% (non-condensing)
11	Casing Material	ABS flame-retardant material
12	Protection Rating	IP33 (temperature detector) / IP23 (smoke detector)
13	Dimensions (Diameter × Height)	Temperature detector: $\Phi 100mm \times 53.3mm$ (including base) Smoke detector: $\Phi 100mm \times 54.5mm$ (including base)
14	Mounting Hole Spacing	45mm ~ 75mm
15	Weight	Temperature detector: ~130g Smoke detector: ~110g

## 2.4.7 Condensed Aerosol



■ **Figure 2-12 Condensed Aerosol**

**Component Description:** The DSPA aerosol generator is a high-efficiency fixed fire extinguishing component, featuring a non-pressure design that allows for direct installation in the confined space to be protected. After activation, the device releases a fully flooded aerosol cloud that quickly spreads to cover the entire protected area, and effectively extinguishes Class A (solid), Class B (liquid), and Class C (gas) fires through the dual effects of chemical suppression and suffocation.

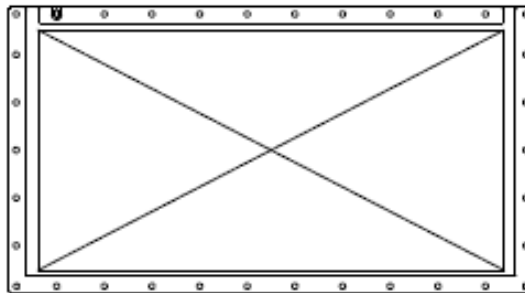
**Table 2-9** Technical Parameters

Model/Spec	Value
Model	11- 3
Part Number	DSPA-ART00013
Dimensions	133×54 mm
Total weight	1300 g
Compound weight	300 g
Volume coverage	2.4~6.9 m <sup>3</sup>
Discharge time	20s
Activation current	Built-in starter, 1.3A
Operation conditions	-40°C~75°C, max. 95% humidity (at 54°C)
Colour	RAL 3000 (standard), other colors are available for customization
Certification	CEN/TR15276-1, NEN-ISO 15779, UL 2775 and BRL K23001

**NOTE**

The following fire protection parts are optional accessories, and can be provided upon request. These accessories will not affect the normal operation of the fire protection system.

### 2.4.8 Explosion Vent Panel



**Figure 2-13 Explosion Vent Panel**

**Component Description:** The explosion vent panel plate is an important safety component of the energy storage cabinet. It is designed to release high-pressure gas and smoke in a controlled manner, preventing the cabinet from exploding in the event of a sudden rise in internal pressure due to battery abnormalities such as thermal runaway or short circuit. The explosion vent panel is installed on the top of the enclosure and is linked with the smoke and temperature detection and fire extinguishing system, creating a multi-layer protection strategy as the last line of defense. It is also used to minimize secondary hazards through directional pressure venting channels, ensuring the safety of both equipment and personnel.

**Table 2-10** Technical Parameters

Model/Spec	Value
ATEX Certification	ATEX II GD - INERIS15ATEX0001X_ Type VL
Protection Level (IP Degree of Protection)	IP65 (compliant with IEC 60529)
Static Pressure (Pstatl)	<500 mbar
Standard Static Pressure (Pstatl standard)	100 mbar +/-15% @22°C
Surface Area (Surface / Area)	5 270 cm <sup>2</sup>
Pressure Change Rate (Kgr)	dp/dt <130 bar/s
Maximum Pressure (Pmax)	<12 bar
Maximum Rated Pressure (Pred, max)	<1.8 bar

Material (In - ox 304L)	Stainless Steel 1.4307
Material (In - ox 316L)	Stainless Steel 1.4404
Gasket (Joint / gasket)	SILICONE UL50E - UL157
Temperature Range (Temperature)	-55...+200 °C

## 2.4.9 Gas Detector ACP



**Figure 2-14 Gas Detector Module**

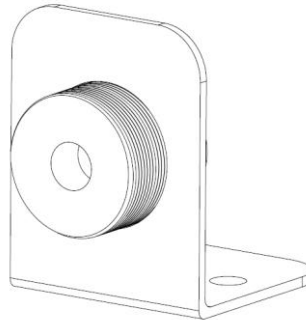
**Component Description:** This module offers a compatible interface for the Li-ion Tamer (LT-SEN-IM), enabling customers to use it independently without the need for an additional controller for Li-ion Tamer detectors. It is suitable for compact energy storage application scenarios, including outdoor energy storage cabinets and independent lithium-ion battery racks. This module facilitates system integration for manufacturers before leaving the factory, eliminating the need for on-site interconnection between cabinets.

**Table 2-10** Technical Parameters

Model/Spec	Value
Operating temperature range	-20°C ~ 70°C
Humidity Range (Non-condensing)	5% ~ 95% RH
Dimensions (H×W×T)	140mm×85mm×32.8mm
Transportation weight	365g
Input Voltage Range	15V ~ 32V DC
Input current	5mA ~ 13mA
Max power	0.5W
Relay Load Capacity	30V DC/125V AC, 2A DC/0.5A AC

RJ45 Output	5V DC, 53mA
-------------	-------------

### 2.4.10 Gas Detector



■ **Figure 2-15 Gas Interface Module**

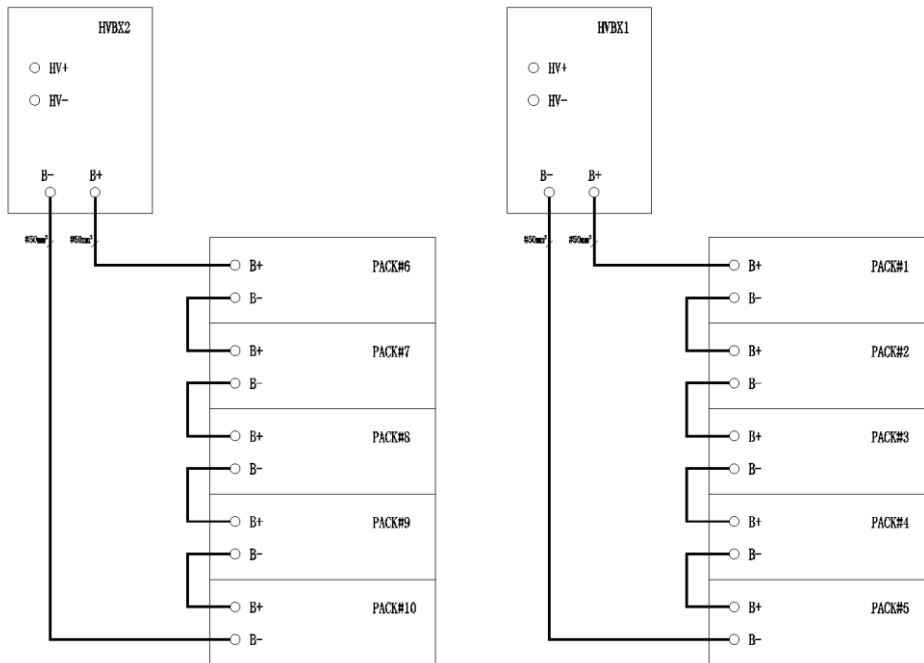
Component Description: The combustible gas detector monitors real-time concentrations of combustible gases (such as methane, propane, and hydrogen) in the environment. When levels reach a preset danger threshold, it immediately activates an audible and visual alarm, cuts off the power supply, or initiates the fire extinguishing system to prevent gas accumulation and mitigate the risk of explosions or fires.

**Table 2-10** Technical Parameters

Model/Spec	Value
Temperature (Operating)	-10 to +60°C
Temperature (Storage)	-10 to +70°C
Humidity	5 to 95% relative humidity
Maximum temperature change	8.6°C per minute
Sensor	Ø 28.6 x 25.4 mm
Monitor cable	165 mm *
Connector type	Female RJ45
Wire type	Brown (Power +)
Wire type	Green/White (Ground)
Wire type	Brown/White (Signal +)
Product Safety	UL/IEC 61010
EMC	EN 60326 - 1 compliant with EU Directive (2014/30/EU)
RoHS	RoHS 3 EU 2015/863

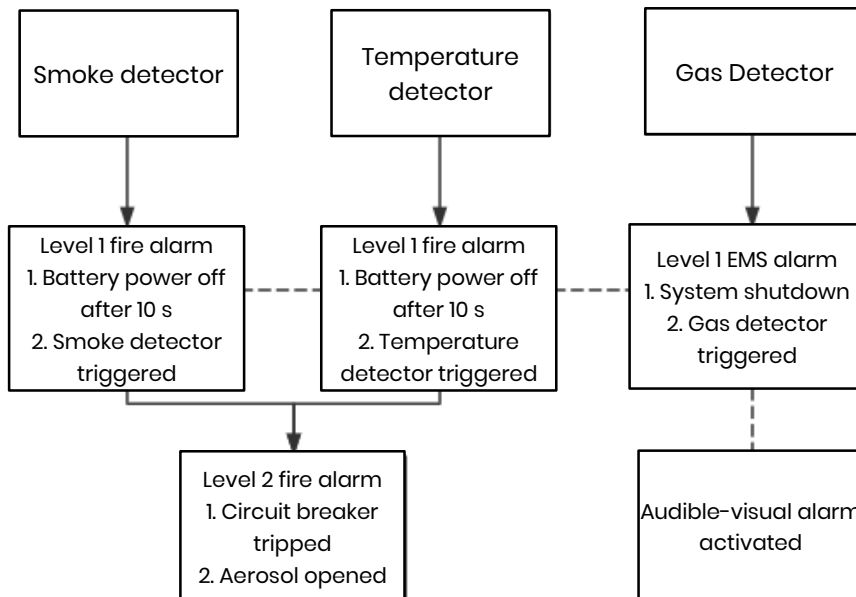
## 2.5. Working Principle

### 2.5.1 Circuit Diagram



■ Figure 2-16 Circuit Diagram

### 2.5.2 Fire Protection Logic Diagram

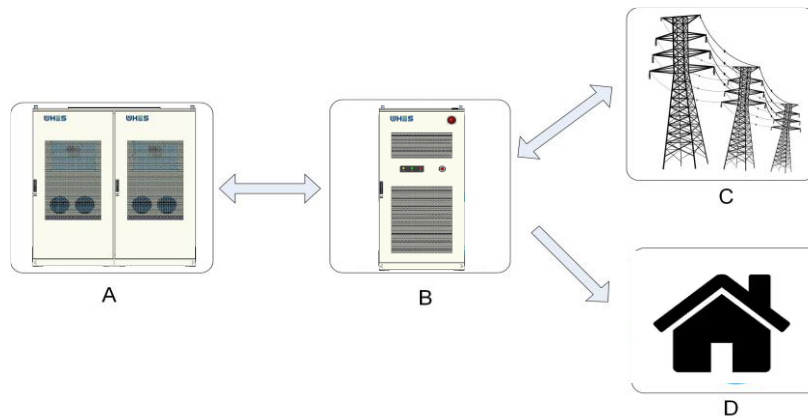


■ Figure 2-17 Fire Protection Logic Diagram

## 2.6 Application Scenarios

The entire ESS station consists of AC 250kW Series Cabinets and DC Battery Cabinet Series, primarily designed for industrial and commercial applications. Specifically:

The AC Cabinet Series adopts an integrated design, incorporating the WH-TAA603 device and power distribution unit to achieve AC/DC power conversion and distribution functions. The DC Battery Cabinet Series integrates battery packs, liquid cooling systems, and fire protection systems, ensuring the safety and efficient operation of energy storage units through an all-in-one framework.



**Figure 2-19 AC Coupling Application Diagram**

Table 2-11 Description of Application Diagram

Identification	Equipment	Description
A	Battery Cabinet DC - 500kWh - EA10	It is used to store energy and is integrated with batteries, liquid cooling, and fire protection systems to achieve, temperature regulation, and fire safety.
B	AC Cabinet AC - 250kW - 1B10 AC - 250kW - 2B10 AC - 250kW - 4B10 AC - 187kW - 1B10 AC - 125kW - 1B10 AC - 125kW - 2B10 AC - 62.5kW - 1B10	It enables the conversion and distribution of power resources, as well as the communication and operation of power distribution and auxiliary systems.
C	Grid	/
D	Load	/

# 3 Site Requirements

## 3.1 Site Selection Requirements

### BEWARE

The site shall be selected in accordance with GB 51048: Design Code for Electrochemical Energy Storage Power Station, NFPA 855: Standard for the Installation of Stationary Energy Storage Systems, and applicable local regulations.

The ESS is designed for outdoor installation. For indoor application, refer to local regulations. General site selection requirements:

- Select the installation site at a high elevation above the maximum historical water level rather than in a low-lying area.
- Maintain a minimum distance of 2 km from airports, landfills, riverbanks, and dams.
- Choose a spacious location and ensure a 10m unobstructed area around the site.
- Maintain a minimum distance of 50 m from residential areas to avoid noise pollution.
- Ensure convenient access to transportation facilities and reliable fire suppression systems.
- Provide sufficient space for current and future needs, including potential expansion throughout the life cycle.
- Choose a well-ventilated location.
- Avoid installing the ESS outdoors in saline areas where the ESS is prone to corrosion and subsequent potential fires. Saline areas refer to areas within 2 km of the coastline or affected by sea winds. Areas affected by sea winds vary based on meteorological conditions (e.g., typhoons, seasonal winds) and terrain features (e.g., dikes, hills).

 NOTE

1. If the selected site fails to meet national standards for safety clearance, it is recommended to select a new site.
2. If no suitable alternative site is available, it is recommended to install a fire wall with a minimum 3 h fire resistance rating for safety, with adequate space for equipment transport, installation and maintenance.
3. According to T/CEC 373-2020, the length and height of the firewall shall extend 1 m beyond the outer perimeter of the prefabricated cabin. According to NFPA855-2020: Standard for the Installation of Stationary Energy Storage Systems, an independent fire wall with a 1 h fire resistance rating allows the spacing to be reduced to 914 mm.

Site selection shall exclude locations, areas, and places that are not recommended by industry standards and regulations, including but not limited to:

- Areas with high vibration, noise, or electromagnetic interference;
- Places where dust, fumes, harmful or corrosive gases are produced or are present;
- Places where corrosive, flammable, or explosive materials are produced or stored;
- Places with existing underground facilities;
- Areas with poor geological conditions, such as rubber soil, soft soil layers, or areas prone to water accumulation and subsidence;
- Earthquake faults and areas with seismic intensity greater than 9 degrees;
- Locations susceptible to direct hazards such as mudslides, landslides, quicksand, or caves;
- Locations affected by mining subsidence (dislocation) hazards;
- Areas affected by explosion hazards;
- Areas at risk of flooding due to dam or dike failure;
- Important water source and sanitary protection zones;
- Historical and cultural relic protection zones;
- Crowded areas, high-rise buildings, and underground structures.

## 3.2 Forklift Requirements

- Ensure that the forklift has a load capacity of at least 6t before using it.
- Recommended fork length:  $\geq 1.8$  m.

# 4 Equipment Installation


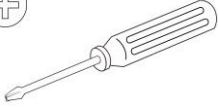
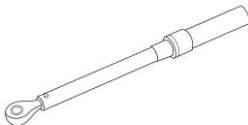
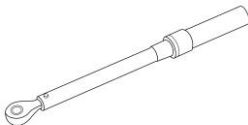

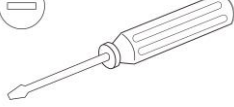
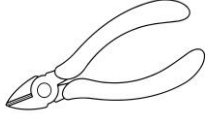
## 4.1 Pre-Installation Preparation

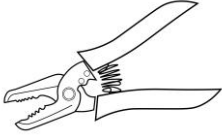
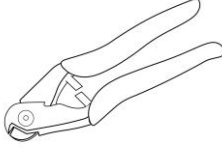

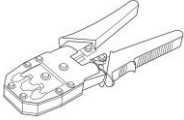
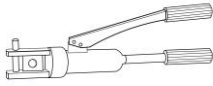

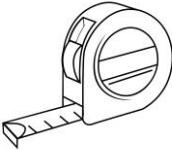


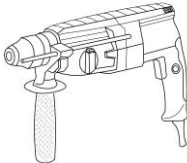

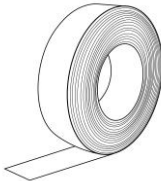
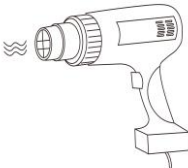
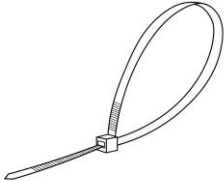

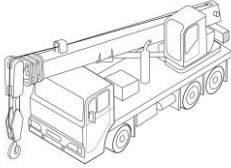
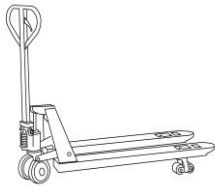

### 4.1.1 Tool Preparation

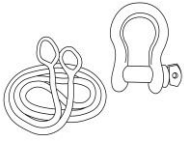



- The illustrated tools are for reference only and may differ from actual tools.
- Due to varying site conditions, this tool list may not be exhaustive. On-site installers and users are responsible for preparing unlisted tools based on actual needs.



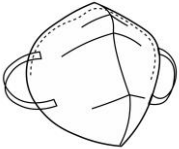


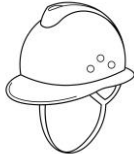
### Installation Tools

 	 	 	
Phillips Insulated Torque Screwdriver	Insulated Torque Socket Wrench (including extension rod) <ul style="list-style-type: none"><li>● Socket size: 7mm~19mm</li><li>● Socket depth: <math>\geq 32</math>mm</li><li>● Socket interface compatible with torque wrench</li><li>● Torque range: 1.2N·m~45N·m</li></ul>	Flathead Insulated Torque Screwdriver	Diagonal Pliers

 <p>Wire Strippers</p>	 <p>Wire Cutters</p>	 <p>Rubber Hammer</p>	 <p>Utility Knife</p>
 <p>Crimping Tool</p>	 <p>Hydraulic Pliers</p>	 <p>Hex Wrench: 5mm~12mm</p>	 <p>Multimeter DC Voltage range ≥1500V DC</p>
 <p>Steel Tape Measure</p>	 <p>Spirit Level</p>	 <p>Vacuum Cleaner</p>	 <p>Impact Drill</p>
 <p>Impact Drill Bit Φ16mm</p>	 <p>Heat Shrink Tubing</p>	 <p>Heat gun</p>	 <p>Cable Tie</p>
 <p>Insulated Ladder</p>	 <p>Crane</p>	 <p>Manual Forklift</p>	 <p>Forklift</p>

 <p>Lifting Rope &amp; Shackle Rope length: ≥2200mm×4</p>	 <p>Crowbar</p>
--	--

### Personal Protective Equipment

 <p>Insulating gloves</p>	 <p>Protective Gloves</p>	 <p>Goggles</p>	 <p>Dust Mask</p>
 <p>Insulating shoes</p>	 <p>Reflective Vest</p>	 <p>Safety helmet</p>	 <p>Seat Belts</p>

## 4.1.2 Pre-Installation Inspection

### Outer Packaging Inspection

Before unpacking the equipment, inspect the outer packaging for visible damage such as holes, cracks, or other signs of possible internal damage, and verify that the product model is correct. If the packaging appears abnormal or the equipment mode does not match, do not open the packaging and contact your dealer immediately.

---

 **NOTE**

It is recommended to remove the outer packaging within 24h before preparing to install the cabinet.

---

 **WARNING**

If the cabinet height exceeds 2 m, ensure appropriate safety precautions for elevated work are in place when removing the outer packaging.

---

### Deliverable Inspection

After unpacking the equipment, inspect all deliverables to ensure they are complete and free of visible damage. If any items are missing or damaged, contact your dealer immediately.

## 4.2 Installing the ESS and Cables

### NOTE

---

** DANGER**

- Before making any electrical connections, ensure that all switches in the ESS are in the "OFF" position. Otherwise, the high voltage of the ESS may cause electric shock hazards.
- Measure the voltage at the contact point before touching any conductor surface or terminal, and confirm that the protective grounding conductor of the equipment or parts to be repaired is securely grounded to ensure that there is no risk of electric shock.

---

** WARNING**

- Equipment damage caused by improper wiring is not covered by the equipment warranty.
- Only qualified electricians can perform electrical connection operations.
- Operators must wear personal protective equipment when making electrical connections.

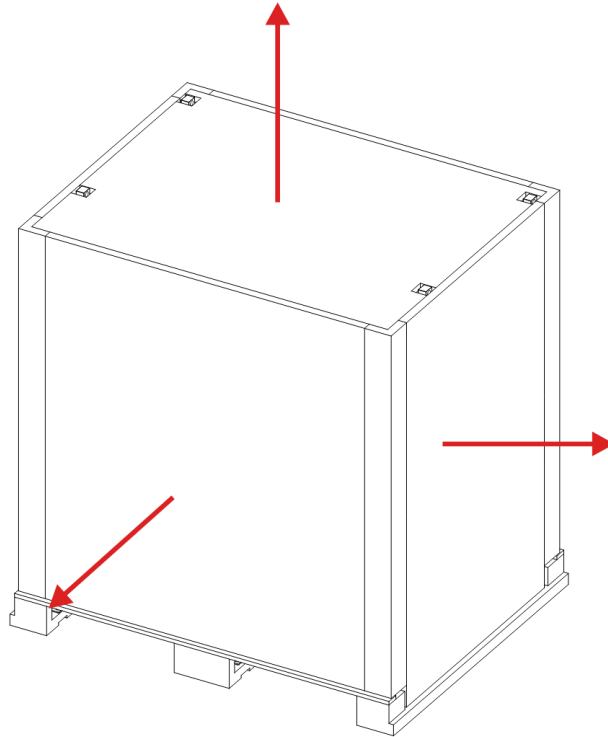
---

** NOTE**

The cable colors shown in all electrical connection diagrams within this section are for reference only. Cables shall be selected according to local cable standards, with yellow-green dual-color wires reserved exclusively for protective grounding).

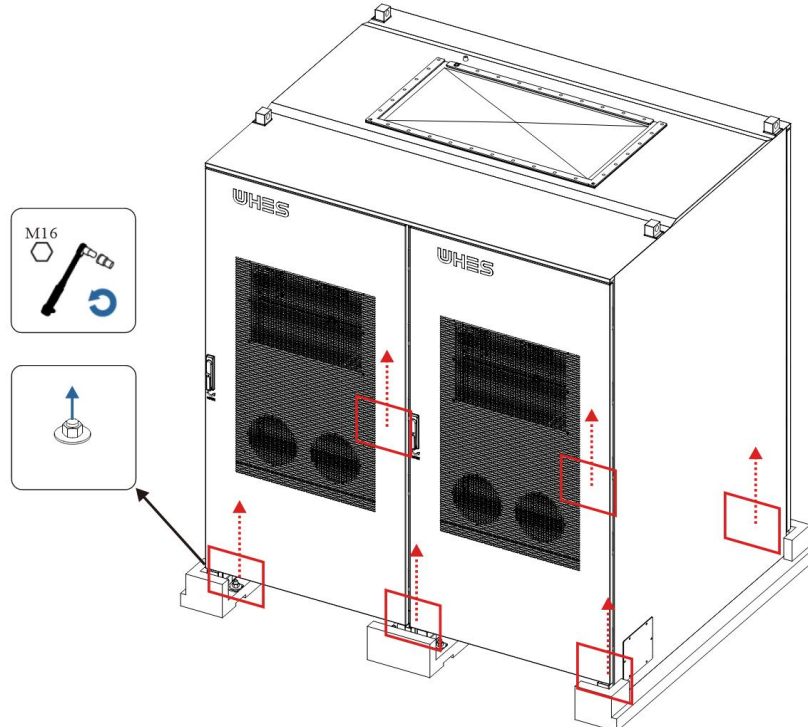
## Installation Procedure

**Step 1** Remove the packaging of the cabinet.



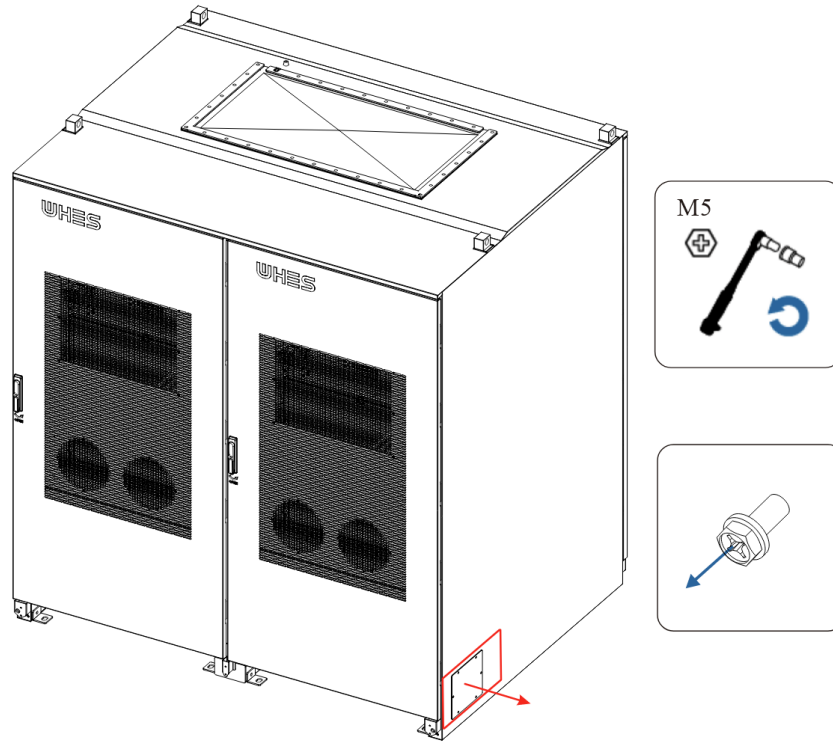
■ **Figure 4-1** Remove the packaging

**Step 2** Remove the wooden pallets.



■ **Figure 4-2** Remove the wooden pallets

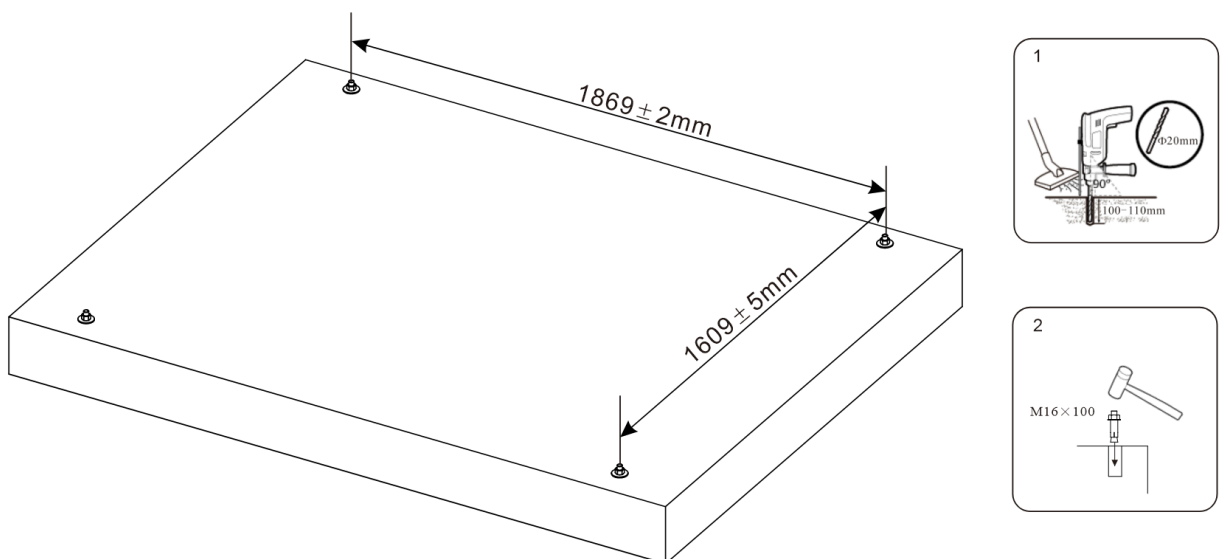
**Step 3** Remove the wire sealing plate.



**Figure 4-3 Remove the wire sealing plate**

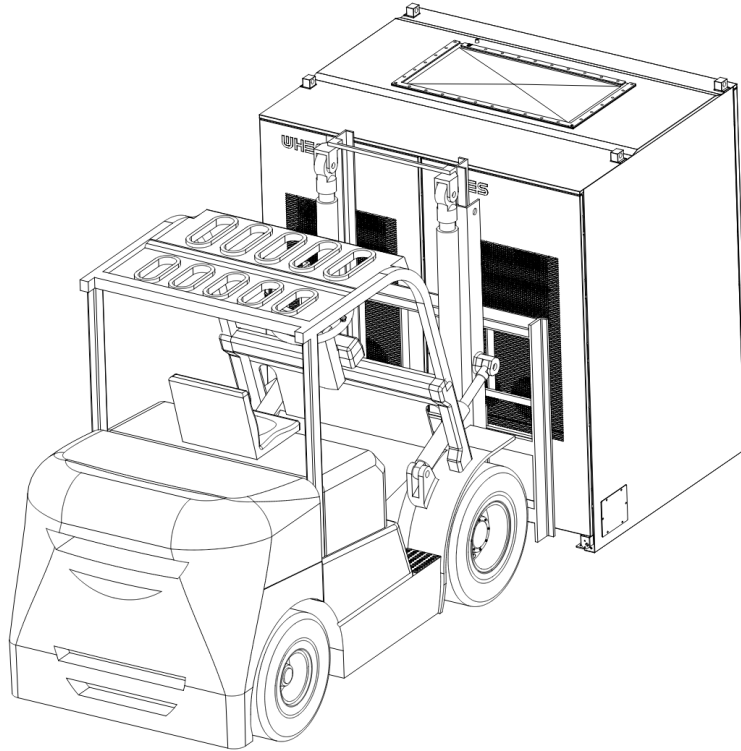
**Step 4** Drill holes on the foundation and install expansion screws (M16×100, 4 pcs in total).

Use an impact drill to drill 4 holes with a diameter of 20 mm and a depth of 65-70mm on the installation foundation. The hole spacing is shown as below. Hammer in four M16×100 expansion bolts. (Exposed thread length above the platform: 30-35 mm)

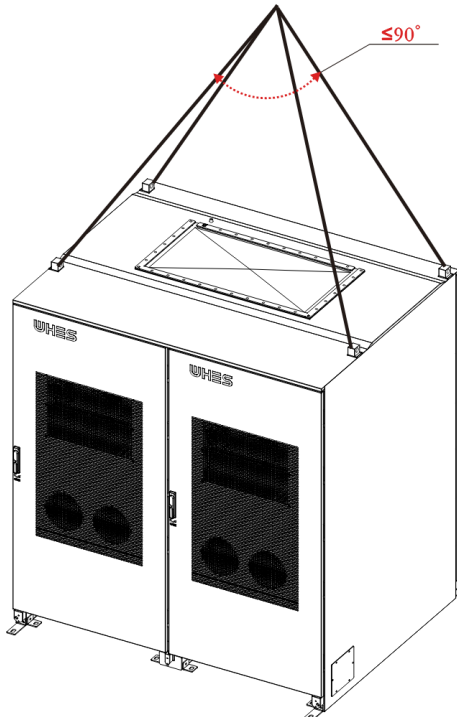


**Figure 4-4 Drill holes on the foundation and install expansion bolts**

**Step 5** Move the cabinet to the mounting platform using a forklift or crane.



■ **Figure 4-4** Move the ESS to the mounting platform using a forklift

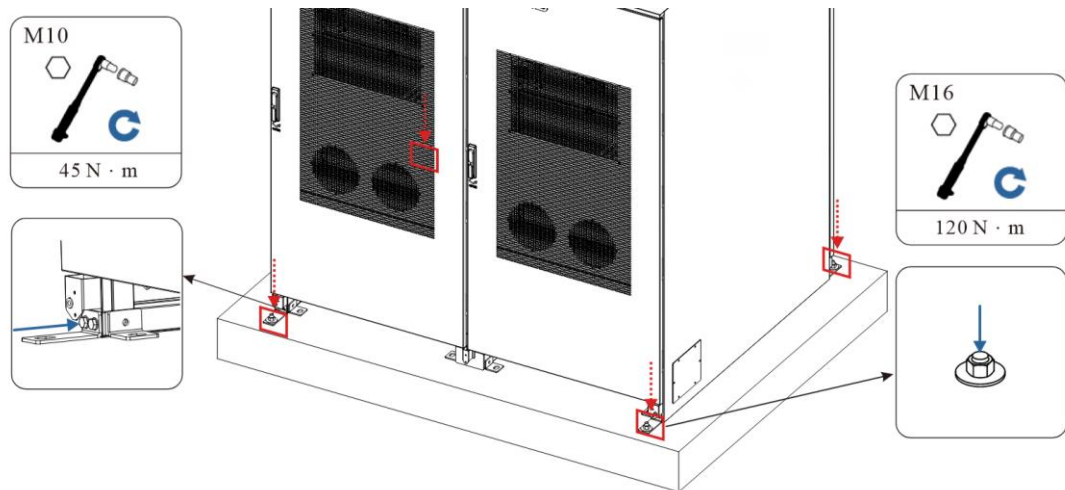


■ **Figure 4-6** Move the cabinet to the mounting platform using a crane

**BEWARE**

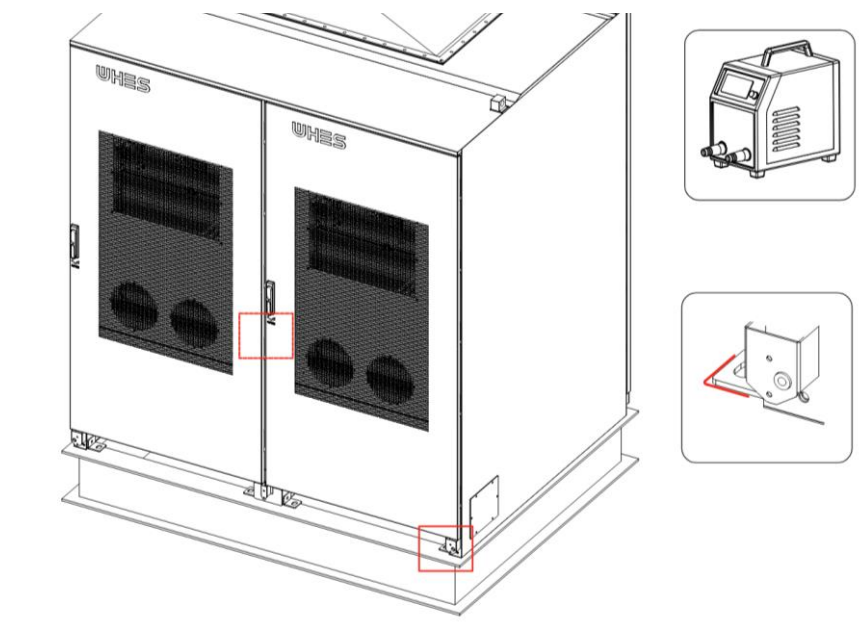
When using a forklift or crane to move the equipment, secure the equipment with appropriate straps based on the actual situation to prevent the risk of overturning.

**Step 6** Install the enclosure fixtures (sheet metal) and mount the system.



■ **Figure 4-7 Install the enclosure fixtures (sheet metal) and mount the platform**

Option 2: Welded to metal base

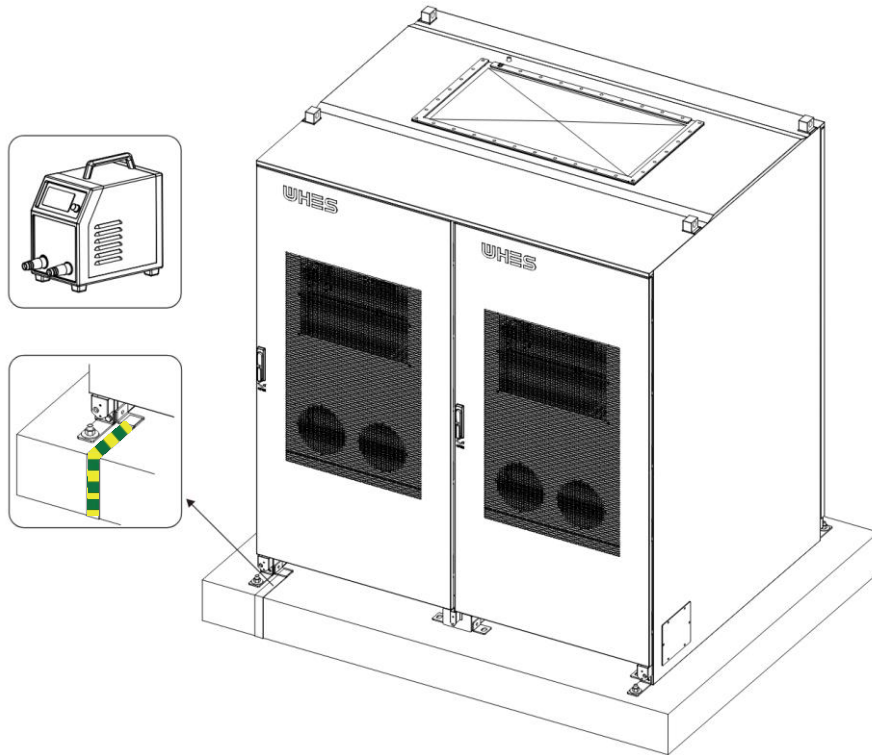


■ **Figure 4-8 Welded to metal base**

**BEWARE**

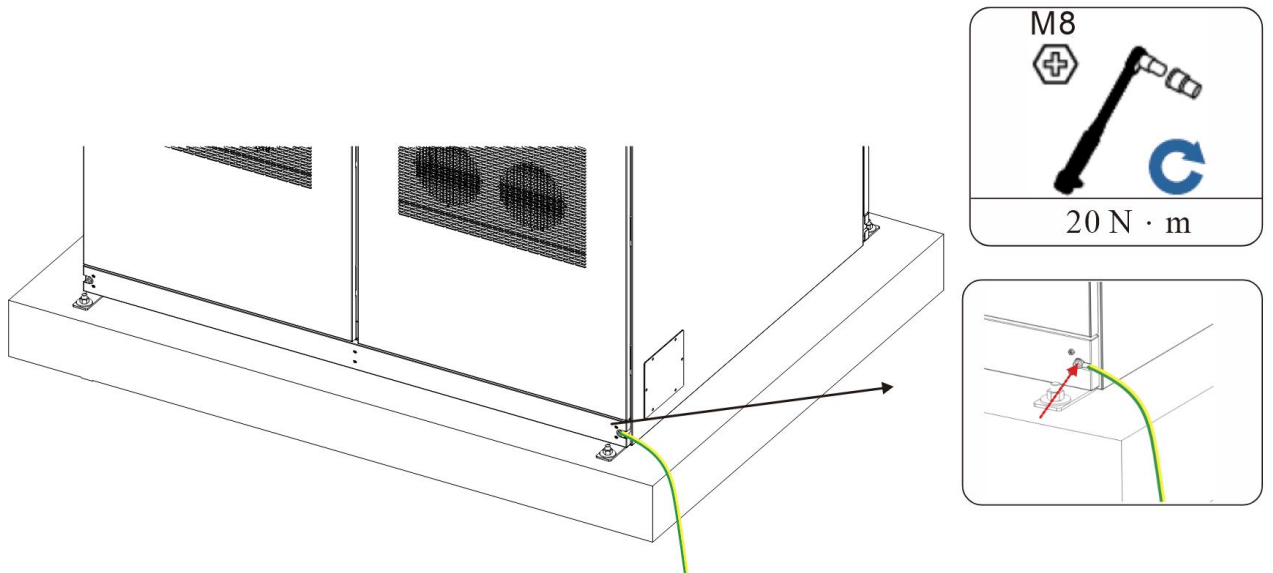
After welding and fixing, it is necessary to promptly apply anti-rust paint such as epoxy primer to the welded areas and their surroundings to form a protective layer. If it is in a humid or corrosive environment, anti-rust grease can be applied additionally to strengthen the protection. Regular inspections should be carried out, and if the paint layer peels off or rusts, clean the area and repaint it in time.

**Step 7** Ground the enclosure.  
Option 1: Weld a grounding busbar.



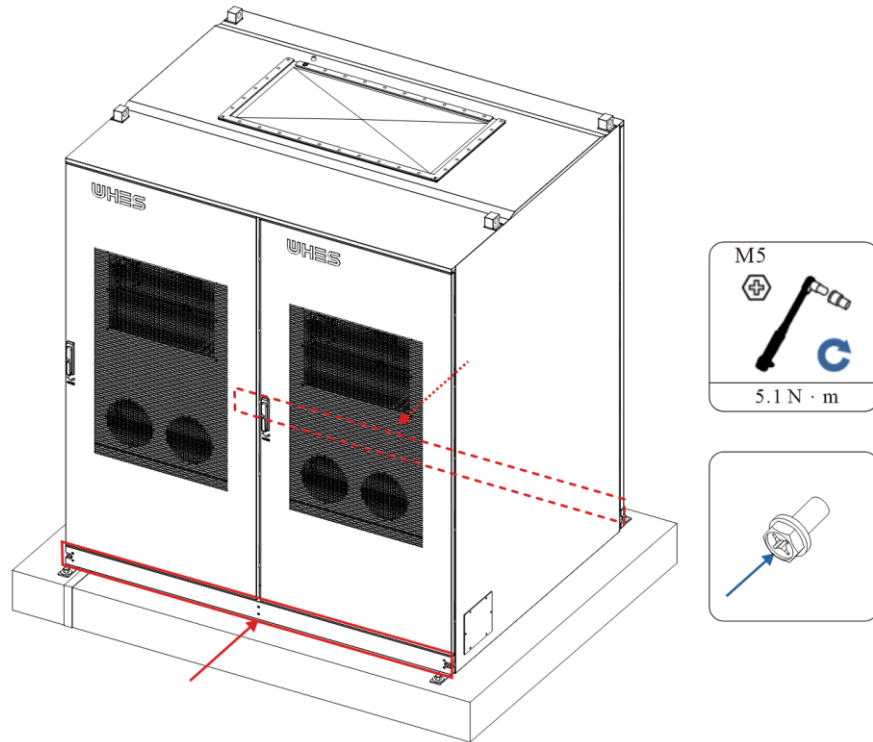
■ **Figure 4-9 Weld a grounding busbar**

Option 2: After completing Step 7, install a grounding wire.



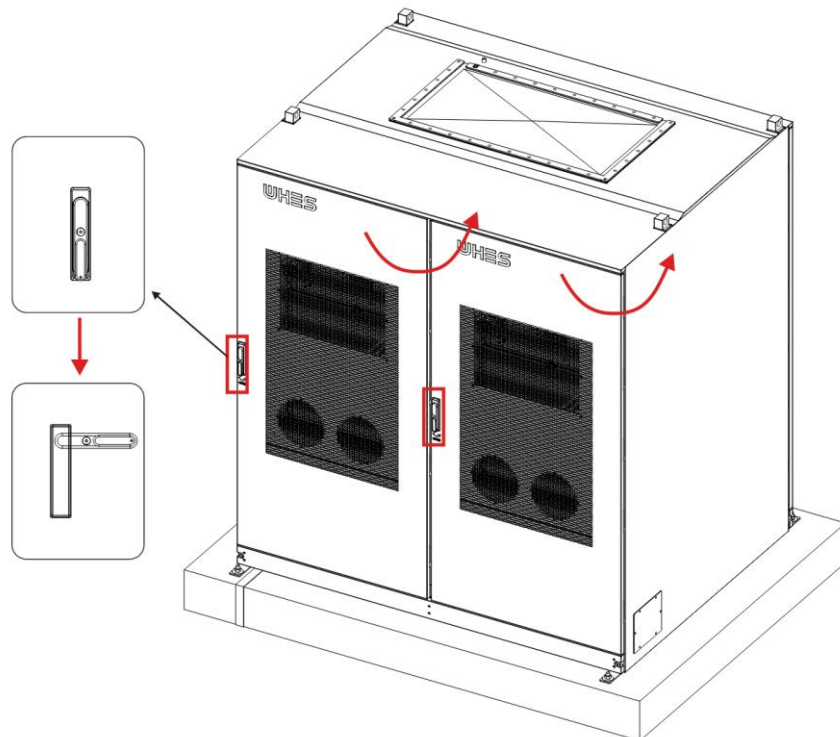
■ **Figure 4-10 Install a grounding wire**

**Step 8** Install the front and rear cover plates.



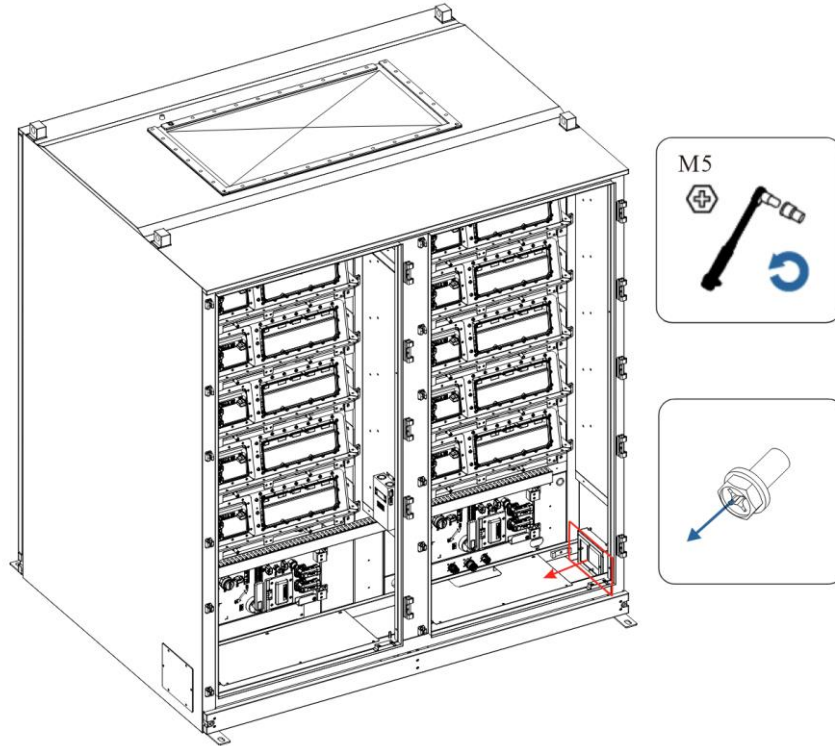
■ **Figure 4-11** Install the front and rear cover plates

**Step 9** Open the front cabinet door.



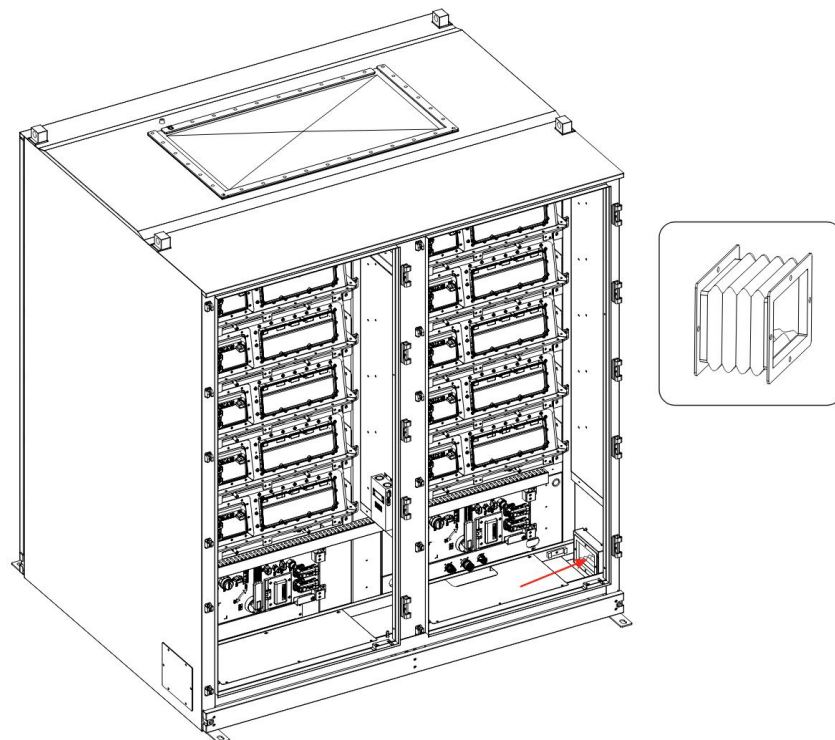
■ **Figure 4-12** Open the front door of the battery compartment

**Step 10** Remove the coil pressure plates (including battery cabinet).



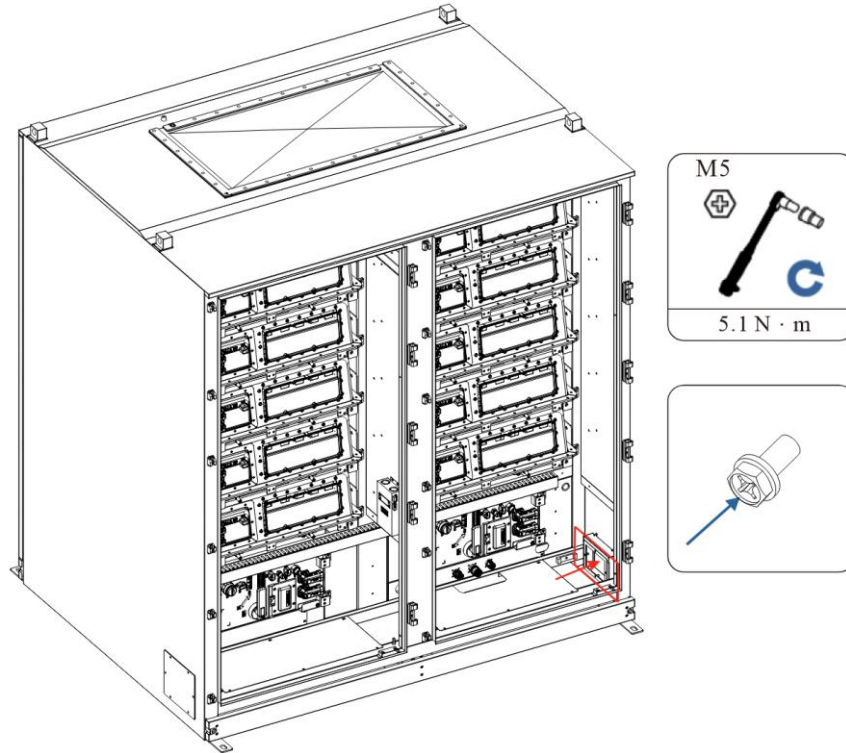
**Figure 4-13** Remove the coil pressure plates

**Step 11** Install the silicone coil.



**Figure 4-14** Install the silicone coil

**Step 12** Install the coil pressure plates (Including battery cabinet).

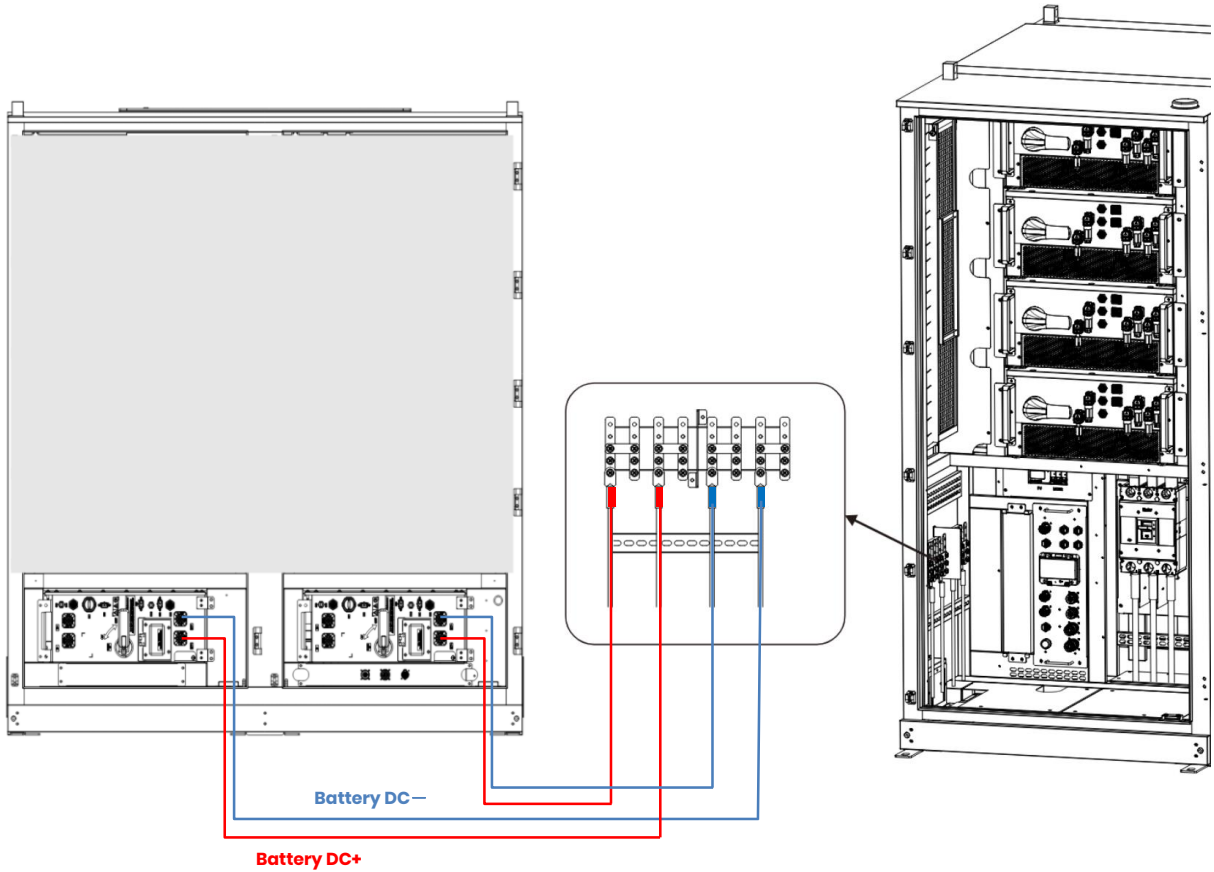


**Figure 4-15** Install the coil pressure plates

**Step 13** Install DC cables

**BEWARE**

The figure below illustrates the installation method for DC cables based on the AC cabinet. For wiring of other the AC cabinet series, please consult our customer service.



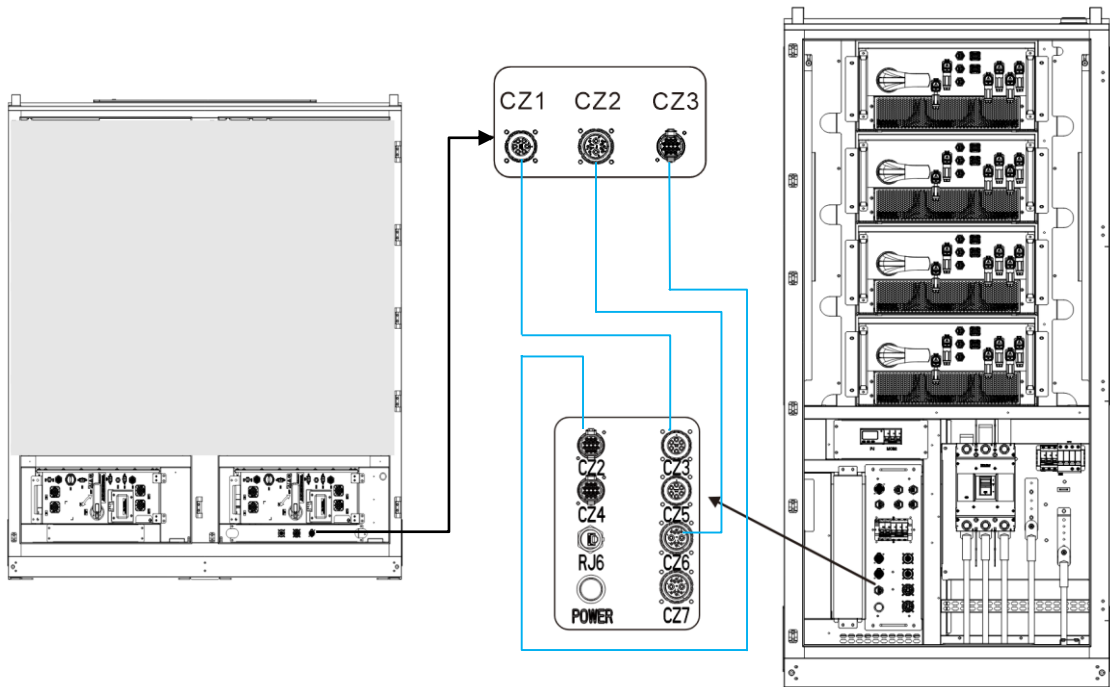
**Figure 4-16** Install the AC/DC cables

**Step 14** Install communication cables.

**BEWARE**

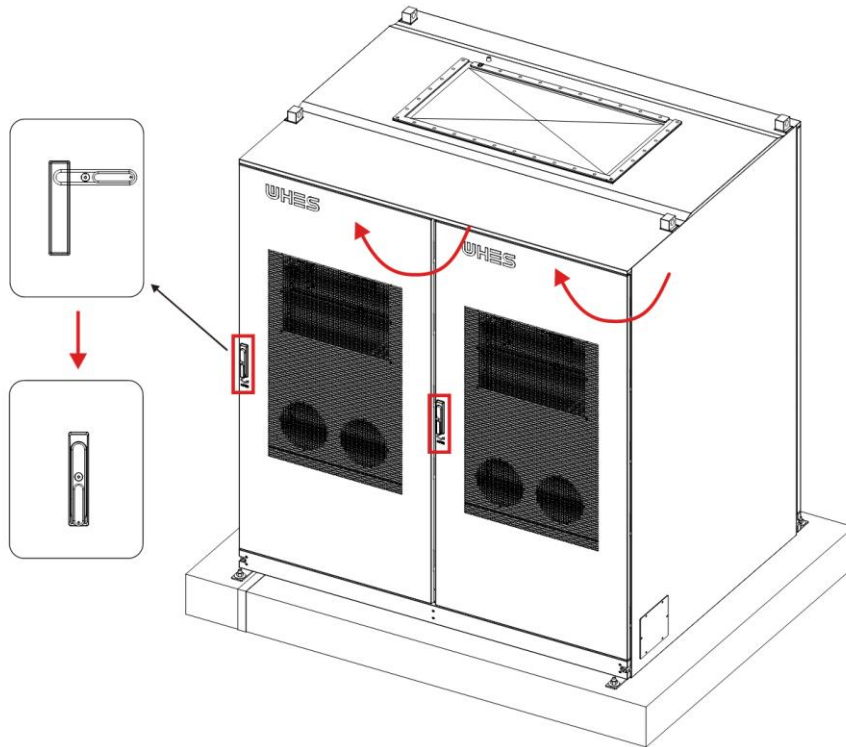
The figure below illustrates the installation method for communication cables based on the AC cabinet. For wiring of other the AC cabinet series, please consult our customer service.

The communication harness is included with the cabinet accessories. If the delivered harness is found to be damaged, please contact our customer service for assistance.



■ **Figure 4-17 Installing communication cables**

**Step 15** Close the front cabinet door.



■ **Figure 4-18 Close the front cabinet door**

# 5 System Power-On

## 5.1 Power-On Inspection

No.	Inspection Item	Acceptance criteria
1	Equipment Appearance	The equipment is intact and free of visible damage, rust, or peeling paint. Repaint any areas with peeling paint.
		All labels on the equipment are clearly visible and legible. Replace damaged labels promptly.
2	Cable Appearance	Cable protective layers are well wrapped and free of visible damage.
		Cable conduits/hoses are intact.
3	Cable Connection	Cable connections are correctly positioned according to the design.
		Terminals are properly installed in accordance with specifications, and connections are secure and reliable.
		All cables are clearly identified at both ends with legible labels that are oriented in a consistent manner.
4	Cable Routing	Cables are routed by separating strong and weak power systems.
		Cabling is organized in a neat and orderly manner.
		Cable ties are trimmed flush, eliminating sharp edges or protrusions.
		Bends are properly managed with sufficient slack, without over-tensioning cables.
		All cables are routed straight and smooth inside the cabinet, avoiding crossovers.
5	Breaker	All circuit breakers in the power distribution cabinet are in the OFF position.
		All breakers in the HV box are in the OFF position. (battery cabinet)

6	Enclosure Grounding	Each enclosure has at least two securely connected grounding points with a maximum contact resistance of $0.1\Omega$ .
7	Identification	Identification is correct, legible, and complete.
8	Sealing of Cable Openings	All cable openings are properly sealed.
9	Battery Pack	All battery pack are free of visible damage.
10	Foreign Objects	All foreign objects such as tools, and leftover installation materials are removed from the cabinet.
11	Power Distribution Area Cover Plate	The cover plates in the power distribution area are free of visible cracks, dents, scratches, breakage, or looseness.
12	Sub-Components (EMS, BMS, UPS, etc.)	All sub-components are free of visible damage.

# 6 Power-On Commissioning (PANGU-LITE)

## Prerequisites

1. All on-site equipment has been fully commissioned upon arrival.
2. The system has been successfully powered on, and all alarms have been cleared.
3. Commissioning devices for startup are available on site.

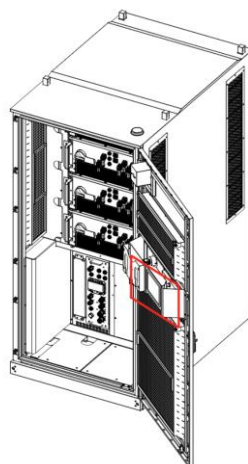
### **i** BEWARE

The figure below illustrates the powered commissioning procedure based on the AC cabinet. For wiring of other the AC cabinet series, please consult our customer service.

## 6.1 Preparation and PANGU LITE Access

### Procedure

As shown in the figure, use the fixed operation display on the door panel of the AC cabinet to enter the PANGU-LITE screen.



**Figure 6-1 Position of the Operation Display**

If the screen fails to appear automatically, activate the browser function shown on the operation display and enter 133.144.155.10:8080/lite to access the PANGU-LITE screen.

## 6.2 HMI Description

### Home Screen:

1. After accessing this screen, you can customize the language, time zone, display settings, and other parameters at the top right corner.
2. This screen shows the direction of energy flow in the system, as well as the real-time operating status of the PCS, battery and grid. The alarm/message system refreshes the operating status and data every 5s.
3. This flow shows the three-phase voltage and current of the grid, the power supply of the PCS, as well as the SOC, voltage and current of the battery.
4. PCS operating conditions:  
Charging: Indicate that the equipment is charging.  
Discharging: Indicate that the equipment is discharging.  
Offline: Indicate that the equipment is in an offline state.  
Standby: Indicates that the equipment is functioning normally without faults and is not in the charging or discharging process.

Inactive: Indicate that the equipment has stopped operating.

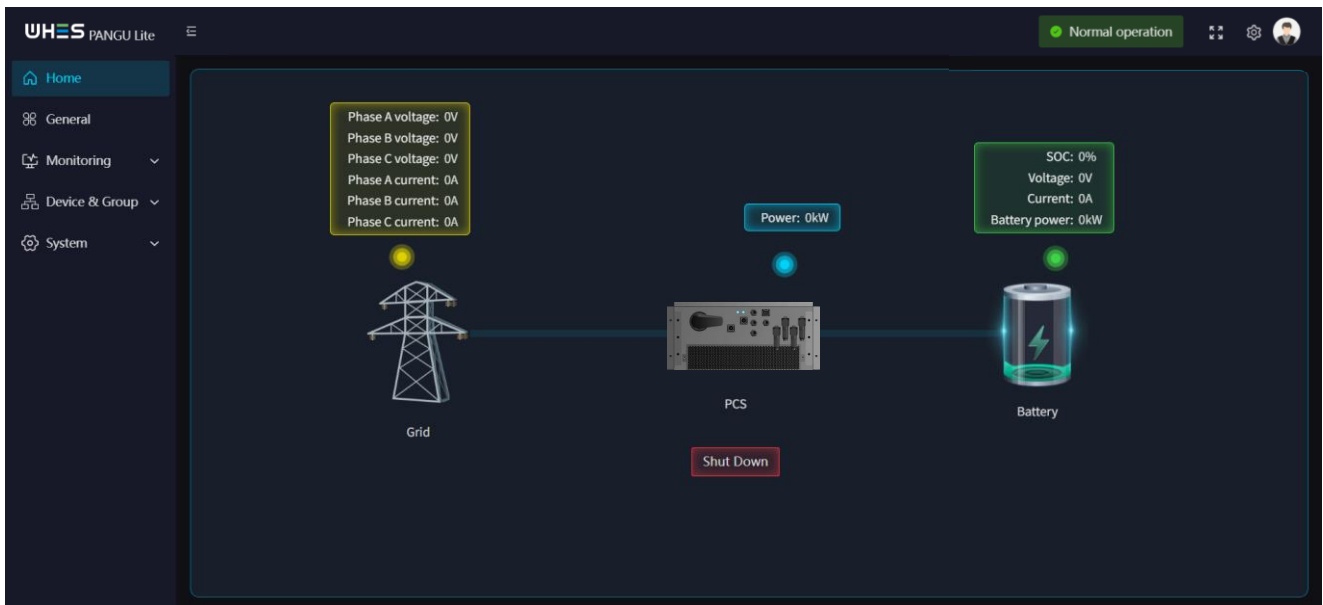


Figure 6-2 PANGU LITE - Home

### Energy Storage Overview:

This screen displays basic system information, including EMS-SN, rated power, rated capacity, maximum charge power, number of PCS units, number of battery clusters, charge/discharge power, available charge/discharge capacity, SOH, and SOC.



**Figure 6-3 PANGU LITE - Overview**

### Operation Monitoring - PCS Screen:

This screen allows real-time monitoring of DC current, DC voltage, and three-phase voltage data, and monitors all operating conditions of the PCS. It also displays operating and simulated data of the PCS, including design capacity, maximum and minimum design voltage, frequency, power factor, active power and reactive power.



**Figure 6-4 Operation Monitoring - PCS Screen**

### Operation Monitoring – BMS Screen:

This screen displays SOC/SOH monitoring information, operating status, and detailed operating data for the battery BMS. It also displays real-time status and data for all battery clusters.

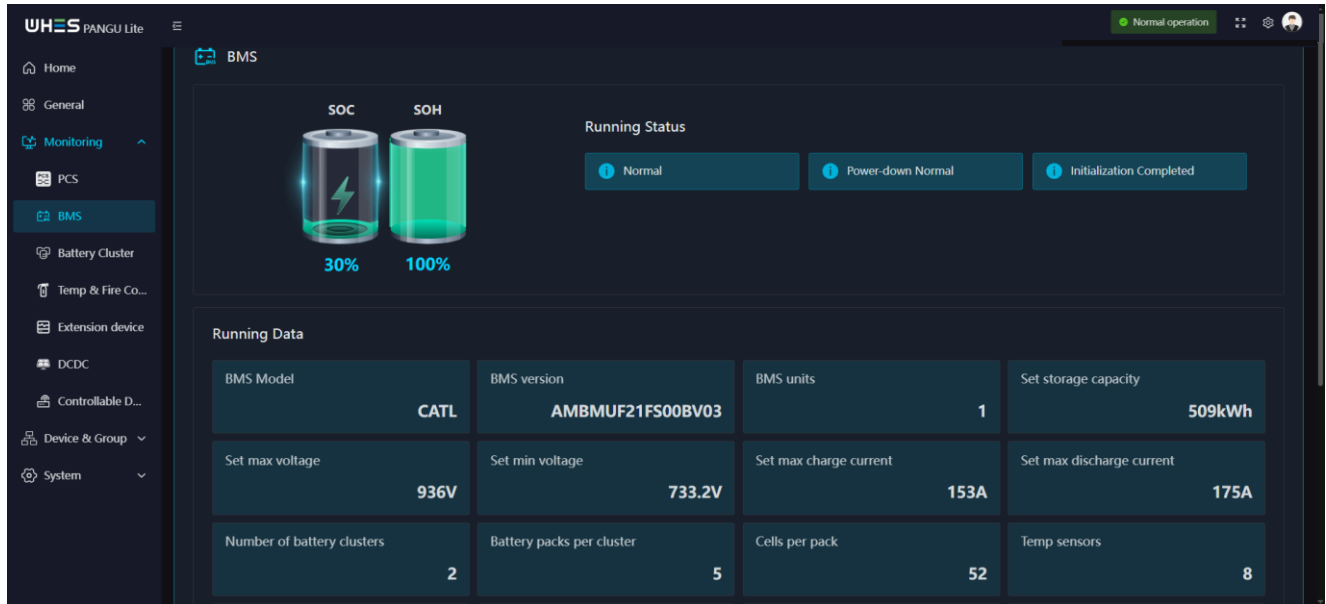


Figure 6-5 Operation Monitoring – BMS Screen

### Operation Monitoring – Battery Cluster Screen:

This screen monitors the voltage and temperature of each battery in the pack, as well as all operating data for the entire battery cluster.

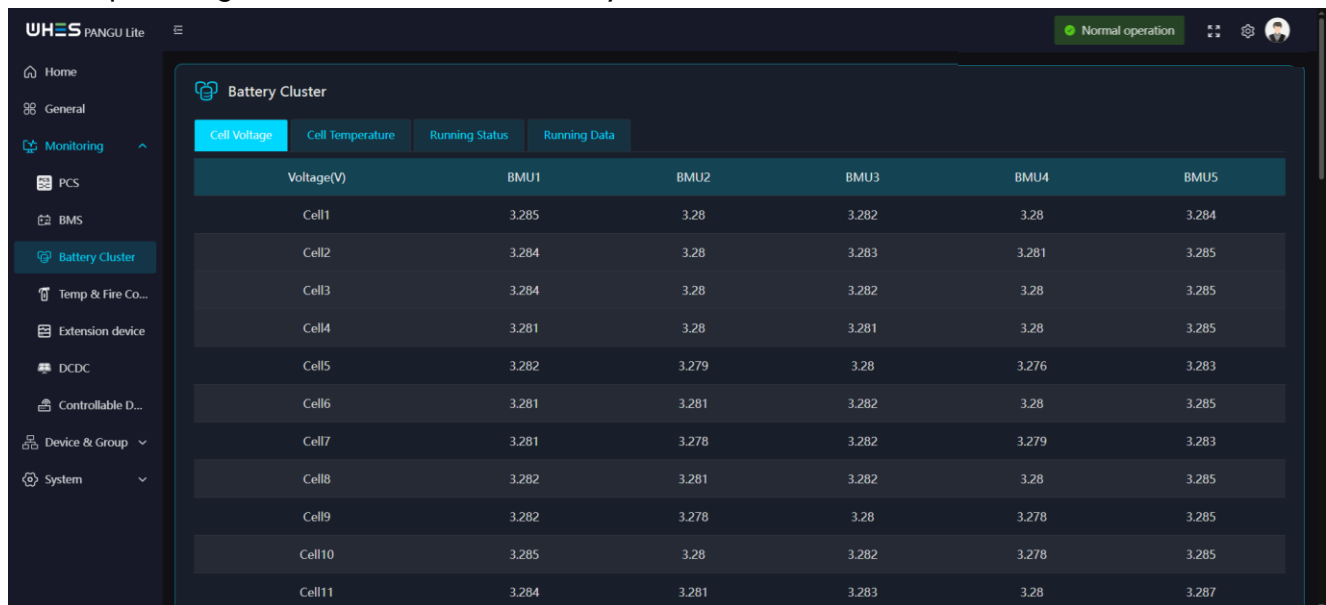
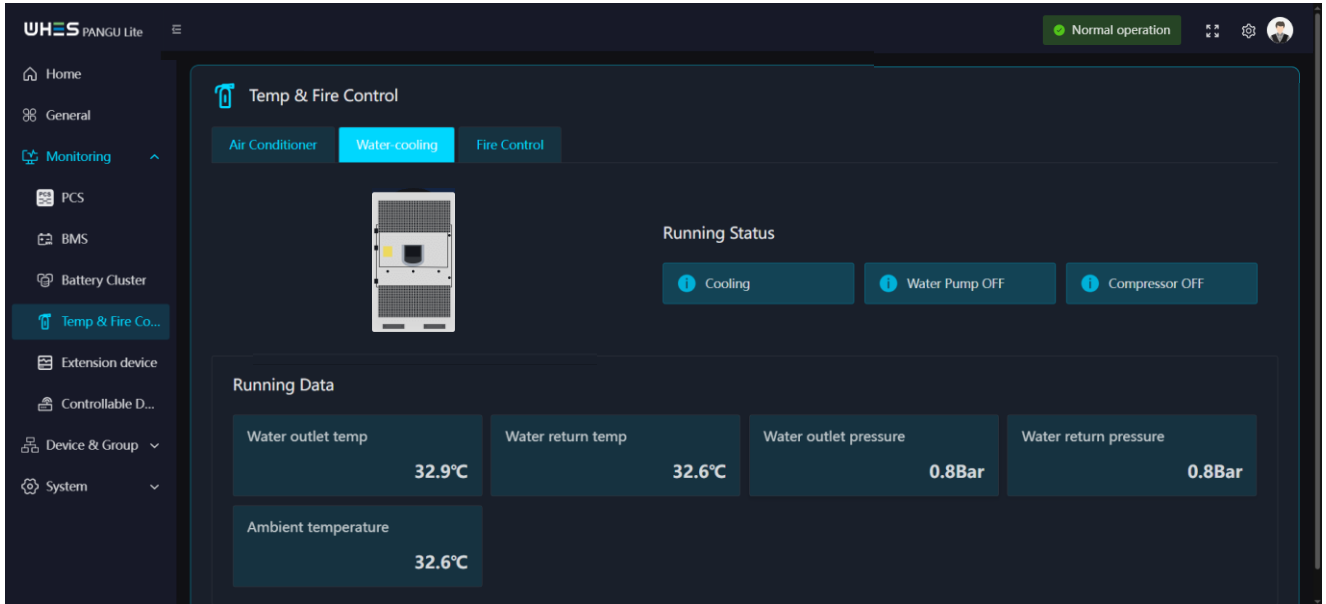


Figure 6-6 Operation Monitoring – Battery Cluster Screen

## Operation Monitoring - Temperature Control & Fire Safety Screen:

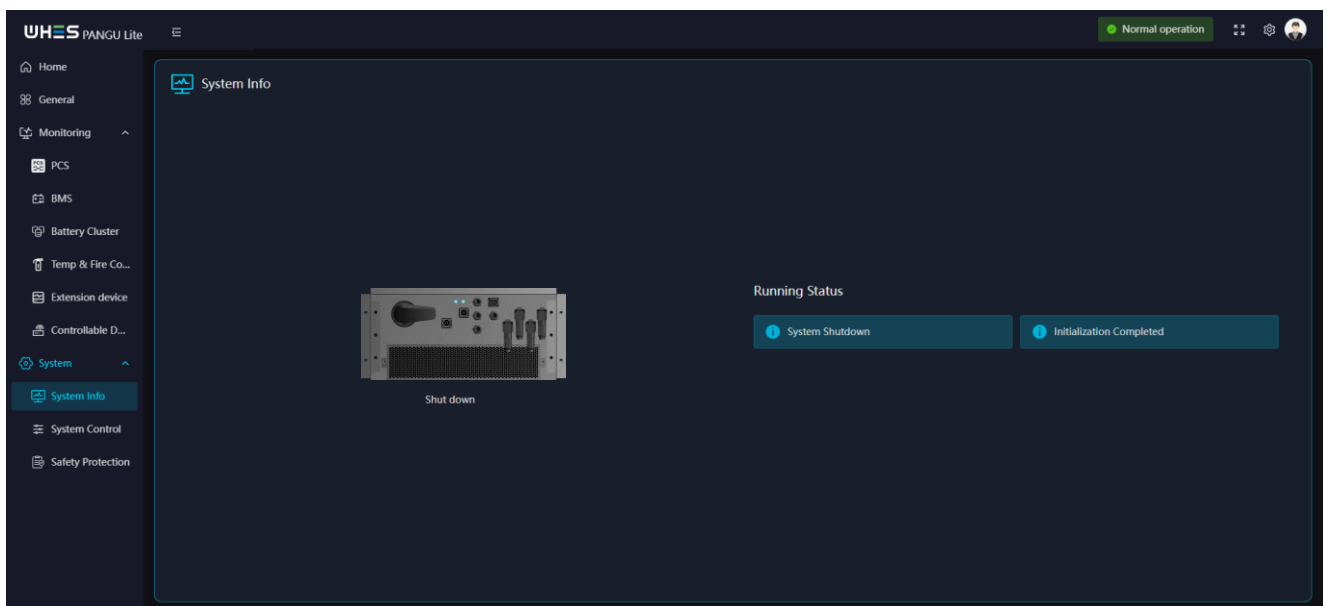
This screen monitors the inlet and outlet water temperature, pressure and operating status of the water chiller system, as well as the operating status of the air conditioning and fire protection systems.



**Figure 6-7 Operation Monitoring - Chiller & Fire Protection Screen**

## System Configuration - System Status Screen:

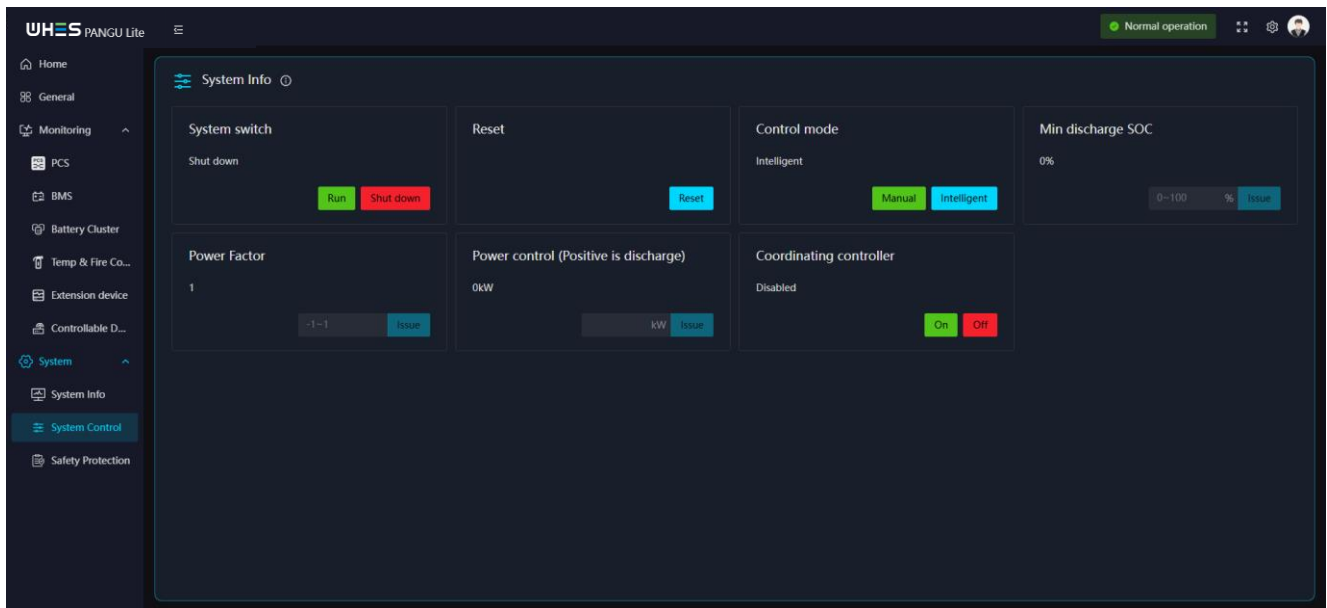
This screen allows you to view the system operating status and perform system control.



**Figure 6-8 System Configuration - System Status Screen**

## System Configuration - System Control Screen:

This screen allows you to control the system, including the system button, reset, grid button, control mode, SOC lower discharge limit, power factor, power control, and coordination control button.

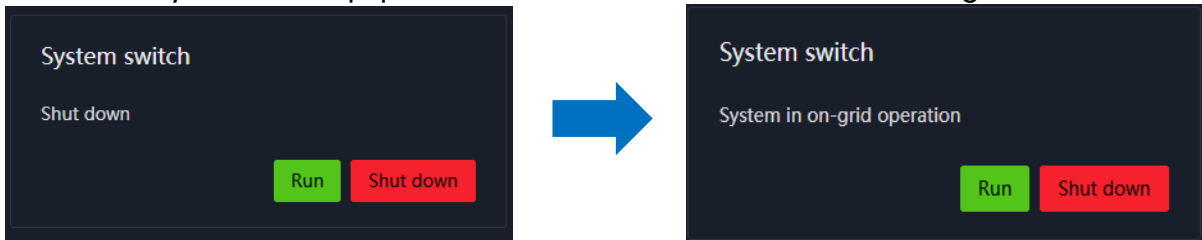


**Figure 6-9 System Configuration - System Control Screen**

## 6.3 Startup Procedure

### Procedure

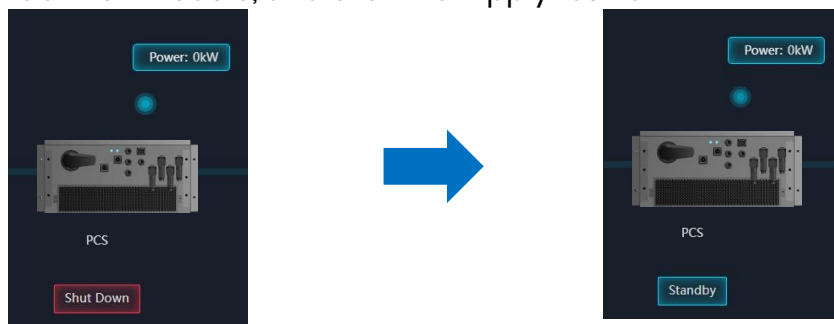
**Step 1** Navigate to "System Configuration > System Control", click the "Start" button, and verify that the equipment status has been buttoned to on-grid mode.



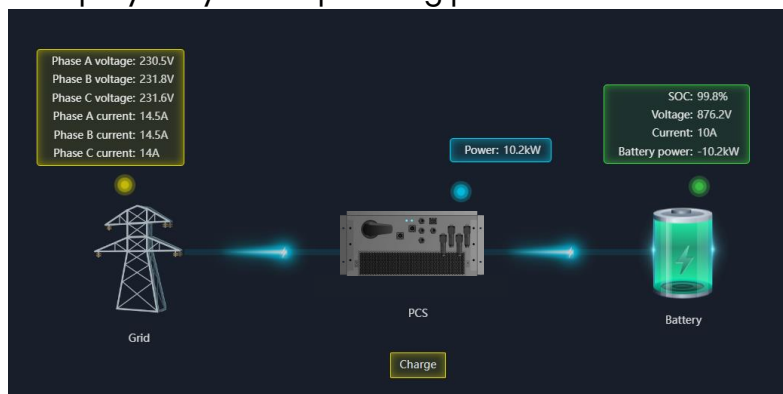
**Step 2** Check the "Home" screen to verify that the PCS is in standby mode.



**Step 3** Navigate to "System Configuration > System Control", enter -10 kW in the "Power Control" module, and click the "Apply" button.



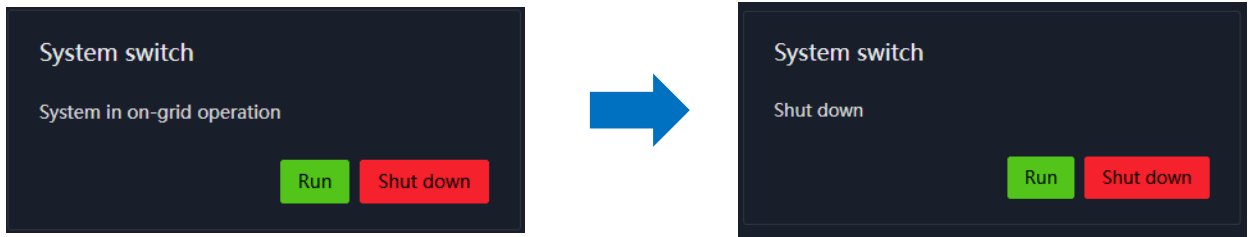
**Step 4** Check the "Home" screen to verify that the PCS is in charging mode, and view the real-time display of system operating power.



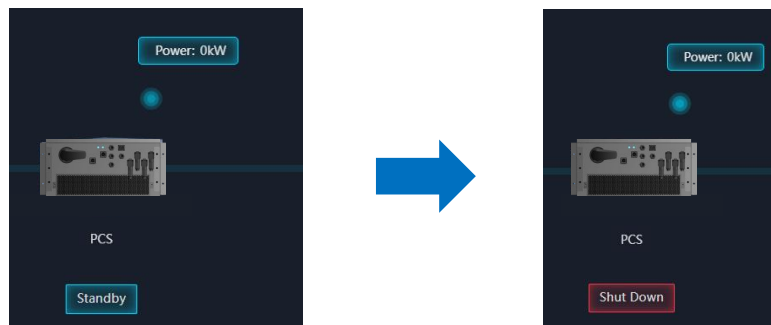
## 6.4 Shutdown Procedure

### Operation Procedures

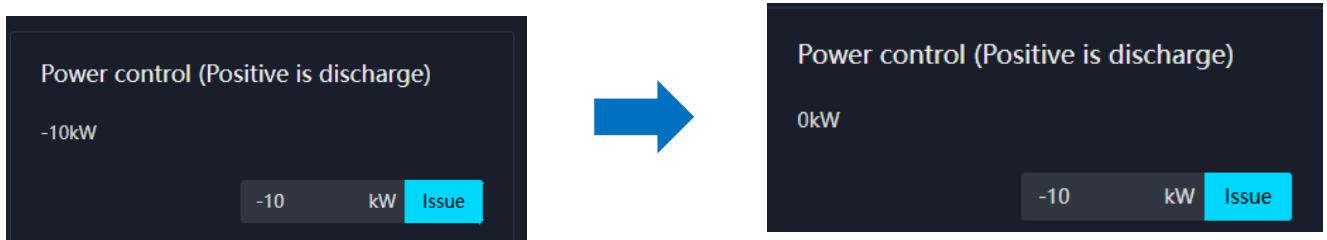
**Step 1:** Navigate to "System Configuration > System Control", enter 0 kW in the "Power Control" module, and click the "Apply" button.



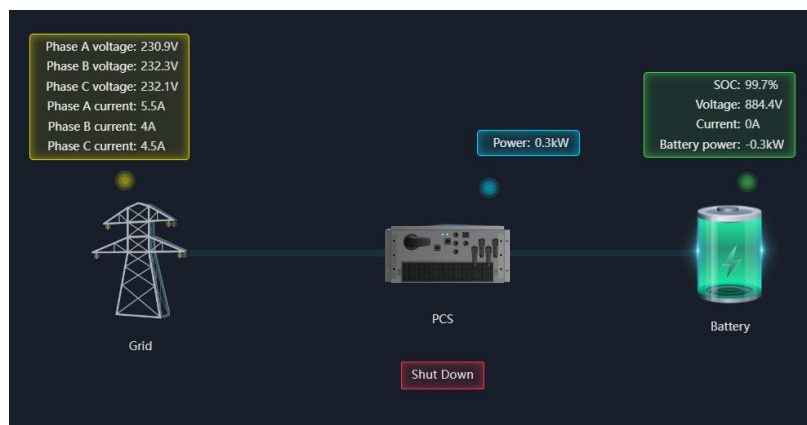
**Step 2:** Check the "Home" screen to verify that the PCS is in standby mode.



**Step 3:** Navigate to "System Configuration > System Control", click the "Stop" button, and verify that the equipment status has been buttoned to inactive mode.



**Step 4:** Check the "Home" screen to verify that the PCS is in inactive mode, indicating that the equipment has been shut down.



# 7 Technical Data

Model	DC - 500kWh - EA10
<b>DC Parameters</b>	
Battery Chemistry	LiFePO4
System Energy	509kWh
Nominal Voltage	832V
Battery Operating Voltage	650~949V
Nominal Capacity	306Ah
Configurations	1P52S*5S*2P
Rated Charging Rate	0.5P
Rated Discharge Rate	0.5P
Maximum charging current	153A
Maximum Discharge current	175A
Charge ambient temperature range	5°C ~ 50°C
Discharge ambient temperature range	-18°C ~ 50°C
Storage temperature range	-20°C ~ 60°C
Standard charging method	The average temperature of cell is maintained at 25±2°C, 0.5P constant power charge to any cell reaches 3.65 V
Standard discharge method	The average temperature of cell is maintained at 25±2°C, 0.5P constant power discharge to any cell reaches 2.5 V
<b>General Parameters</b>	
IP Rating	IP55
Operating Humidity Range	0~95% (non-condensing)
Noise	<70dB @1 meter
Operating Temperature Range	-20°C ~ +55°C

Cooling Method	Liquid cooling
Altitude	2000m
Dimensions (W*D*H)	1940mm*1500mm*2100mm
Weight	~4.5t
<b>Auxiliary power supply</b>	
Normal Voltage	L-N 230V
Frequency	50/60Hz
Max. cont. Power	6kW

# 8. Product Maintenance

## 8.1 Terminology Definition

- Normal operation: Refers to a system that operates daily.
- Intermittent operation: Refers to a system that operates at an irregular monthly frequency and cannot guarantee daily operation.
- Long-term storage: Refers to a battery system that has not been activated for more than 5 consecutive months (the battery system should be charged to 50% SOC before suspending use).

## 8.2 Requirements for Normal System Operation

- Perform battery maintenance on the system every 12 months to prevent battery damage. Refer to Section 9.6 for specific maintenance instructions.
- Conduct a patrol inspection for the ESS every 12 months (refer to Appendix 1) and maintain inspection records.

## 8.3 Requirements for Intermittent System Operation

- The requirements are the same as those for normal operation of the system.

## 8.4 Requirements for Long-Term System Storage

- Energy storage battery storage SOC range: 30%~50%. Avoid long-term storage of cells below 15% SOC. When batteries are not used for a prolonged time, disconnect power-consuming devices promptly.
- Conduct a patrol inspection for the ESS every 5 months (refer to Appendix 1) and maintain inspection records.
- Perform battery maintenance on the system every 5 months to prevent battery damage. (Refer to Section 9.6 for specific maintenance instructions).
- Before the first use of a long-term stored system, perform at least one full charge cycle to activate the battery system and restore battery performance to its optimal state.

Tips
Long-term storage of the ESS may lead to irreversible battery damage. It is important to ensure regular maintenance.

## 8.5 Battery Maintenance Instructions

To ensure the safe and reliable long-term operation of your ESS, please read and follow the instructions below:

Maintenance Procedure:

Scheme 1: This power saving scheme is recommended when the battery system is at a low SOC level.

1. Discharge the battery system to the cut-off condition (average cell voltage  $<3.1\text{ V}$  or minimum voltage  $<2.8\text{ V}$ ), then stop discharging and let it rest for 1 h.
2. Perform an automatic full charge on the battery system (maximum cell voltage  $>3.65\text{ V}$ ). After charging is complete, let it rest for 1 h.
3. Discharge the battery system to 50% SOC and then stop discharging.

Scheme 2: This power saving scheme is recommended when the battery system is at a high SOC level.

1. Perform an automatic full charge on the battery system (maximum cell voltage  $>3.65\text{ V}$ ). After charging is complete, let it rest for 1 h.
2. Discharge the battery system to the cut-off condition (average cell voltage  $<3.1\text{ V}$  or minimum voltage  $<2.8\text{ V}$ ), then stop discharging and let it rest for 1 h.
3. Charge the battery system to 50% SOC and then stop charging.

### Tips

1. Before performing maintenance, verify that the environment and system are in a safe condition, with no alarms or faults present.
2. After completing battery maintenance on the ESS, you can notify Weiheng After-sales Service for free data analysis.

## 8.6 Liquid Cooling System Maintenance and Service Requirements

- a) The coolant recommended by Weiheng is SoluKing SK-E50-B -40°C.
- b) It is strictly forbidden to inspect or repair the unit while it is energized. Wait more than 15 min after the unit is powered off before repairing or disassembling the unit.
- c) Third-party coolants not approved by Weiheng are not recommended. If used, they must comply with the coolant standards specified in Table 8-1. Damage to the battery cabinet components caused by using coolants other than those recommended by Weiheng will not be covered by the warranty.
- d) The coolant is typically an alkaline solution, and its alkalinity will gradually diminish over time with use. It is recommended to check the coolant concentration every six months. If the pH value is lower than 6.5 or higher than 9.5, please consult our customer service for assistance.
- e) Use disposable pH test strips for testing. Immerse the strip in the coolant for 0.5 s, then remove it and compare it to a standard color chart to determine the pH value.
- f) The coolant sample for testing can be collected by inserting an 8 mm OD tube into the inspection port.
- g) Sampling should be performed with the system powered off, and 20-30 mL of coolant is required for a single test. Excessive discharge of coolant may result in insufficient fluid in the chiller, which may affect normal operation.

**Table 8-1** Coolant Requirements

Model/Spec	Value
pH	7.5-8.5
Conductivity	200-3000 $\mu\text{S}/\text{cm}$
Evaporation Residue	< 500 mg/dm <sup>3</sup>
Deposition	< 3 mg/dm <sup>3</sup>
Ca + Mg	0.5-2 mmol/l
Bicarbonate	1-5 mmol/dm <sup>3</sup> (60-300mg/dm <sup>3</sup> )
Free Carbon Monoxide	< 10 mg/dm <sup>3</sup>
Sulphide	< 0.01 mg/dm <sup>3</sup>
Chlorides	< 50 mg/dm <sup>3</sup>
Sulphates	< 250 mg/dm <sup>3</sup>
Nitrates	< 25 mg/dm <sup>3</sup>
Nitrite	< 0.1 mg/m <sup>3</sup>

# A Crimping OT/DT Terminals

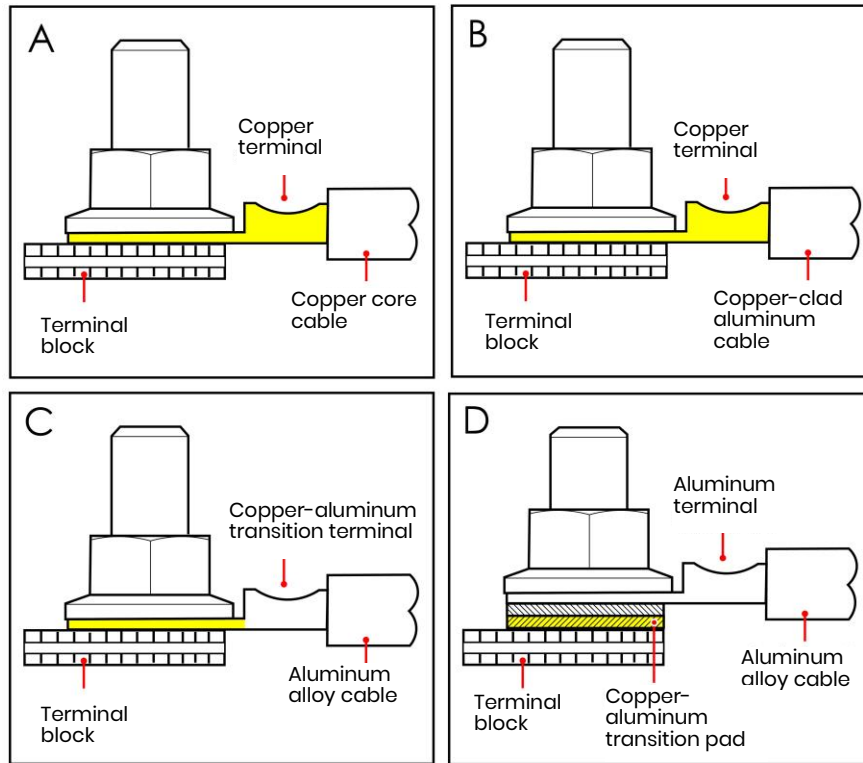
## OT/DT Terminal Requirements

- For copper core cables, please use copper terminals.
- For copper-clad aluminum cables, copper terminals are required.
- For aluminum alloy cables, use copper-aluminum transition terminals, or aluminum terminals with copper-aluminum transition pads.

---

 **BEWARE**

- It is strictly forbidden to connect aluminum terminals directly to terminal blocks, as this may cause electrochemical corrosion and affect the reliable cable connection.
  - When using copper-aluminum transition terminals, or aluminum terminals with copper-aluminum transition pads, ensure compliance with IEC61238-1.
  - When using copper-aluminum transition pads, ensure proper orientation so that the aluminum side of the pad contacts the aluminum terminal, and the copper side contacts the terminal block.
-

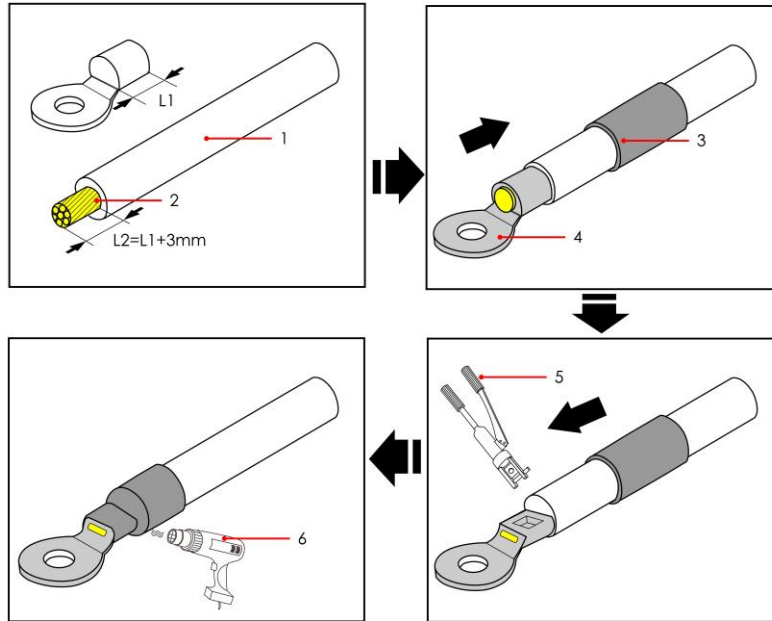


■ **Figure A-1 OT/DT Terminal Requirements**

## Crimping OT/DT Terminals

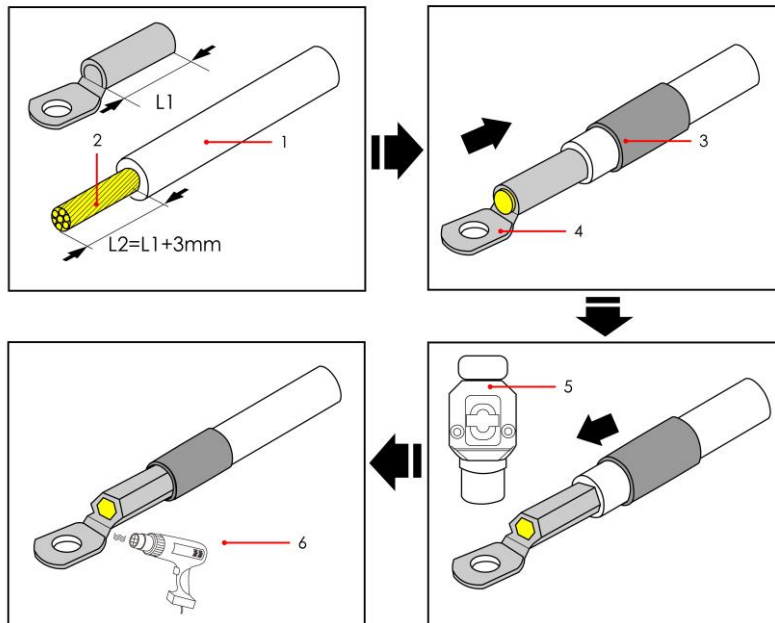
### **BEWARE**

- Do not scratch the conductor when stripping the cable.
- The cavity formed by the conductor crimping tab of the OT/DT terminal after crimping shall completely enclose the conductor, and the conductor shall be tightly connected to the OT/DT terminal without any looseness.
- The crimped area can be covered with heat shrink tubing or insulating tape. Below is an example of using heat shrink tubing.
- When using a heat gun, pay attention to safety precautions to prevent damage to the equipment.



■ **Figure A-2 Crimping OT Terminal**

- |                 |                               |                 |
|-----------------|-------------------------------|-----------------|
| (1) Cable       | (2) Conductor                 | (3) Heat shrink |
| (4) OT terminal | (5) Hydraulic crimping pliers | (6) Heat gun    |



■ **Figure A-3 Crimping DT Terminal**

- |                 |                               |                 |
|-----------------|-------------------------------|-----------------|
| (1) Cable       | (2) Conductor                 | (3) Heat shrink |
| (4) DT terminal | (5) Hydraulic crimping pliers | (6) Heat gun    |

# B How to Repaint

## Prerequisites

- Repainting outdoors without shelter is strictly prohibited in severe weather conditions such as rain, snow, strong winds, sandstorms.
- The paint required for repainting has been prepared according to the color chart delivered with the equipment.

## Cabinet Color

- Top cover and base: RAL 7046, small orange peel texture
- Enclosure and other sheet metal parts: RAL 7035, small orange peel texture

## Repainting Instructions

Maintain the intact appearance of the equipment by repainting any paint loss immediately.



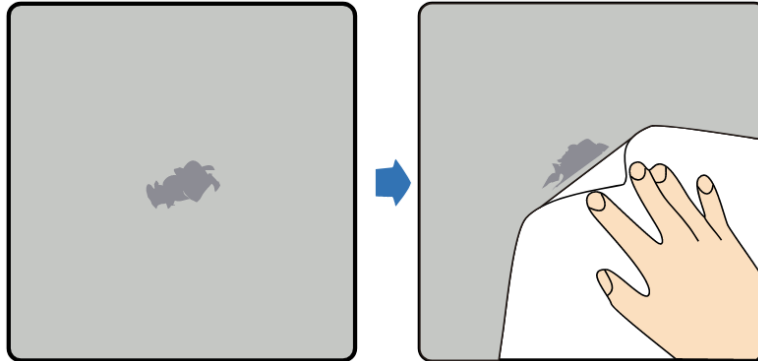
Visually inspect the extend of paint damage and prepare the necessary tools and adequate materials according to actual needs on site.

**Table A-1** Repainting Instructions

Paint Damage	Tools & Materials	Procedure	Description
Shallow scratches (without exposure of steel substrate) Non-wipeable stains and rust	Hand spray paint or paint, brush (for small area repainting), fine sandpaper, anhydrous ethanol, cotton cloth, spray gun (for large area repainting).	Follow Steps 1 + 2 + 4 + 5.	1. Use the color chart delivered with the equipment to match the topcoat (acrylic paint) color to the specified Pantone number.
Deep scratches (primer damaged, steel substrate exposed)	Hand spray paint or paint, zinc-rich primer, brush (for small area repainting), fine sandpaper, anhydrous ethanol, cotton cloth, spray gun (for large area repainting).	Follow Steps 1 + 2 + 3 + 4 + 5.	2. For minor scratches, small stains, and rust, hand spray or brush painting is recommended.
Logo and pattern damage or dents	For damaged logos and patterns, provide the logo dimensions and color code, and contact a local advertising and painting service provider to develop and execute a repair scheme based on the logo dimensions, color and damage situation.  1. For dents with an area less than 100 mm <sup>2</sup> and a depth less than 3 mm, fill them with unsaturated polyester resin putty (Poly-Putty base) and then follow the repainting procedure for deep scratches.  2. For dents with an area greater than 100 mm <sup>2</sup> or a depth greater than 3 mm, find a local supplier to provide a separate repair scheme based on the actual situation.		3. For extensive scratches, large stains and rust, use a spray gun to apply the paint.  4. Apply a thin, even coat of paint where practical, avoiding droplet formation and ensuring a smooth surface.  5. Allow the repainted surface to dry for approximately 30 min before proceeding with subsequent operations.

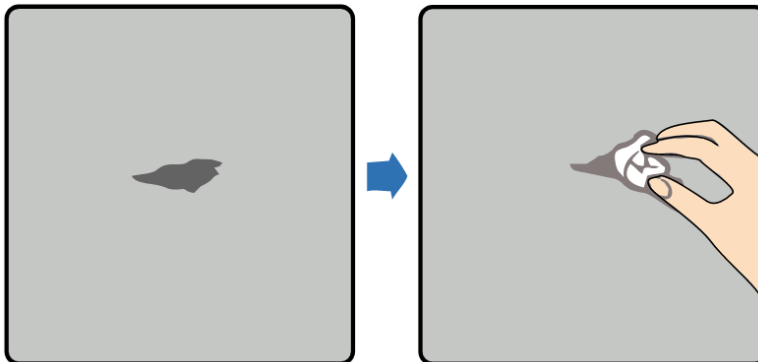
## Procedure

**Step 1** Use fine sandpaper to gently sand the damaged area to remove any stains or rust.



■ **Figure B-1 Sanding Damaged Coating with Fine Sandpaper**

**Step 2** Wipe the sanded area or the area to be repaired with a cotton cloth dampened with anhydrous ethanol to remove surface dirt and dust. Then wipe it dry with a clean cotton cloth.



■ **Figure B-2 Treating Damaged Coating with Anhydrous Ethanol**

**Step 3** Apply a zinc-rich primer to the damaged coating using a brush or spray gun.

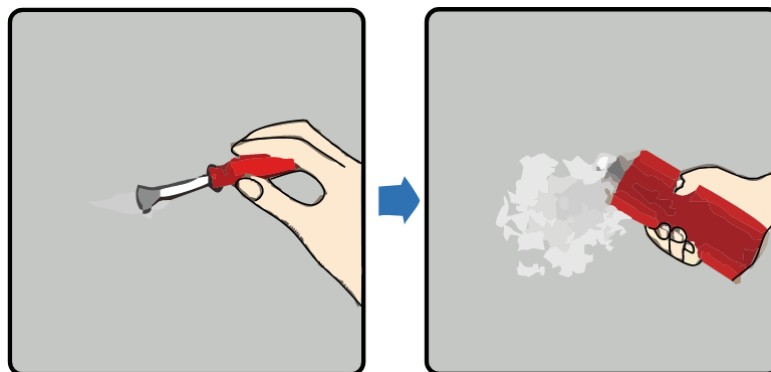
**i BEWARE**

- If the substrate is exposed in the area to be repaired, apply an epoxy zinc-rich primer and allow it to dry completely to cover the substrate. Then apply an acrylic topcoat.
- Select an epoxy zinc-rich primer or acrylic topcoat of the appropriate color to match the surface finish of the equipment.

**Step 4** Depending on the extent of the paint damage, choose one of the following methods: self-spraying, brushing, or spray gun application. Apply the paint evenly to the damaged area until no trace of coating damage is visible.

**i BEWARE**

- Apply a thin, even coat of paint where practical, avoiding droplet formation and ensuring a smooth surface.
- For equipment with multi-colored patterns, mask the areas with other colors using tape and white paper before repainting to prevent contamination.



**Figure B-3 Repainting Damaged Coating on Equipment**

**Step 5** Allow the brush-painted area to dry for approximately 30 min, then inspect for compliance with the requirements.

**NOTE**

- The repainted area must match the color of the surrounding area. Use a colorimeter to measure the color difference ( $\Delta E \leq 3$ ). If a colorimeter is unavailable, visually inspect the repainted area to ensure a seamless blend with the

surrounding area, free of any visible edge. The coating must be free of bumps, scratches, peeling, or cracks.

- For spray painting, it is recommended to spray three coats and then observe whether it meets the requirements. If not, repeat the spraying process until the requirements are met.

# C How to Recycle Used Batteries

---

## BEWARE

- Weiheng does not provide battery recycling services. Customers are responsible for contacting local recyclers for disposal.
- If no local service is available, customers are advised to contact the nearest national recycler for disposal.

---

**Step 1** Contact the nearest recycler.

**Step 2** The recycler evaluates the recycling cost.

**Step 3** The recycler recycles batteries using one of the following two methods:

- On-site recycling: The recycler collects lithium batteries from the customer site, at a price determined based on the actual travel distance/transportation cost and other factors.
- Centralized recycling: The customer brings all lithium batteries to be recycled to a designated location for centralized collection by the recycler.

## NOTE

Transportation cost arising from the on-site recycling service is to be borne by the customer.

**Step 4** The recycler is fully responsible for the disposal of the recycled batteries. The recycler takes full responsibility for disposing of the recycled lithium batteries, with no further involvement from the customer.

# D Contact Details

Please contact us if you have any questions about this product.

**Table D-1** Customer Service Contact Details

Country	E-mail	Phone
China	service@whes.com	+86 4008776999

# **E** Abbreviations

## B

BMS Battery Management System

## C

CAN Controller Area Network

## E

EMS Energy Management System

## L

LAN local area network

## S

SOC state of capacity

SBMU Secondary Battery Control Unit

## U

UPS uninterruptible power system

# F Install

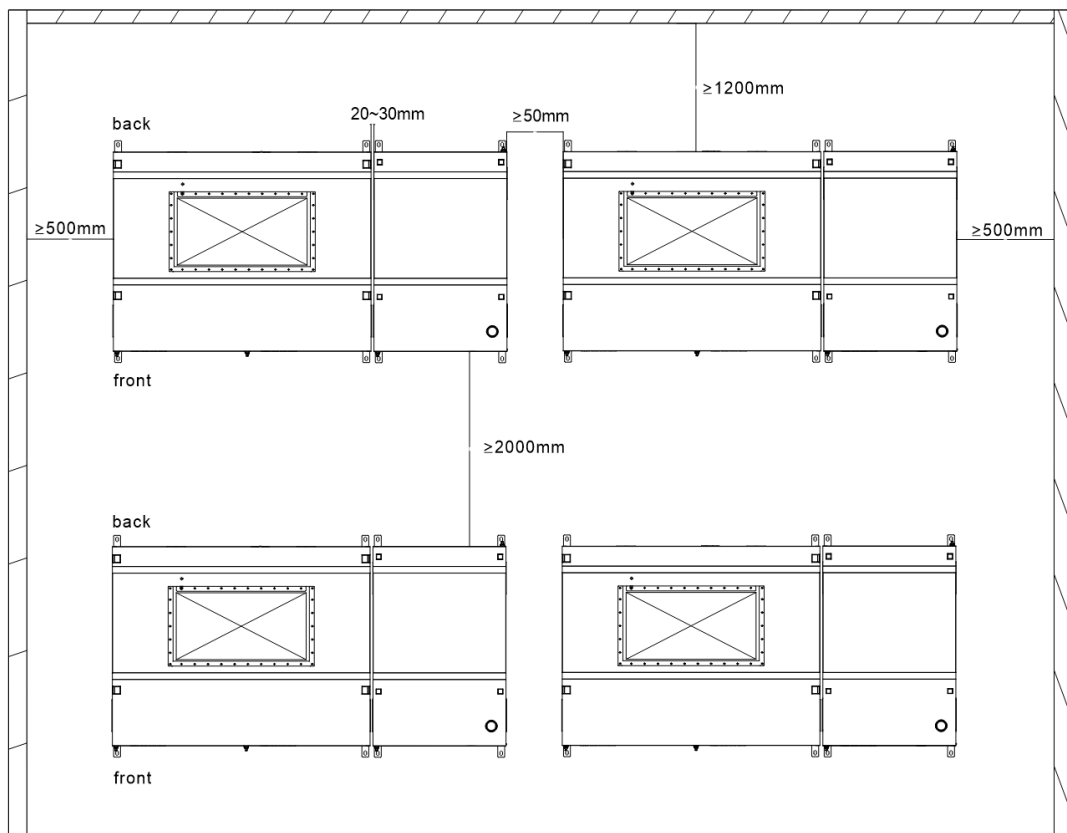
## Design requirements for foundation scheme:

- The energy storage system must be installed on a concrete or non-combustible surface. It is necessary to ensure that the installation plane is level, stable, flat, and has sufficient bearing capacity. There must be no depressions or tilts.
- The equipment foundation is configured based on the total weight of the equipment. If the local foundation's load-bearing capacity does not meet the requirements, it needs to be rechecked.
- The bottom of the equipment foundation pit must be compacted and leveled.
- After the equipment foundation is excavated, it is strictly prohibited to soak it and disturb it. If it is disturbed by soaking, it should continue to be excavated and backfilled.
- The horizontal error of the contact surface between the equipment foundation and the cabinet body must be  $\leq 3\text{mm}$ .
- The foundation must be higher than the local historical highest water level and at least 300mm higher than the horizontal ground.
- Drainage facilities should be constructed in combination with the local geological conditions and municipal drainage requirements to ensure that no water accumulation occurs at the equipment foundation. The foundation construction should meet the drainage requirements for the local maximum rainfall, and the discharged water needs to be treated in accordance with local laws and regulations.
- When constructing the equipment foundation, it is necessary to consider the possibility of problems with the cables of the energy storage system and reserve trenches or incoming line holes.
- The reserved holes for the equipment foundation and the incoming line holes at the bottom of the equipment should all be sealed.
- The foundation drawing cannot be used as the final construction drawing and is for reference only. Users must recheck the design parameters of the energy storage system

foundation according to the installation environment, geology, and seismic requirements of the project site.

**BEWARE**

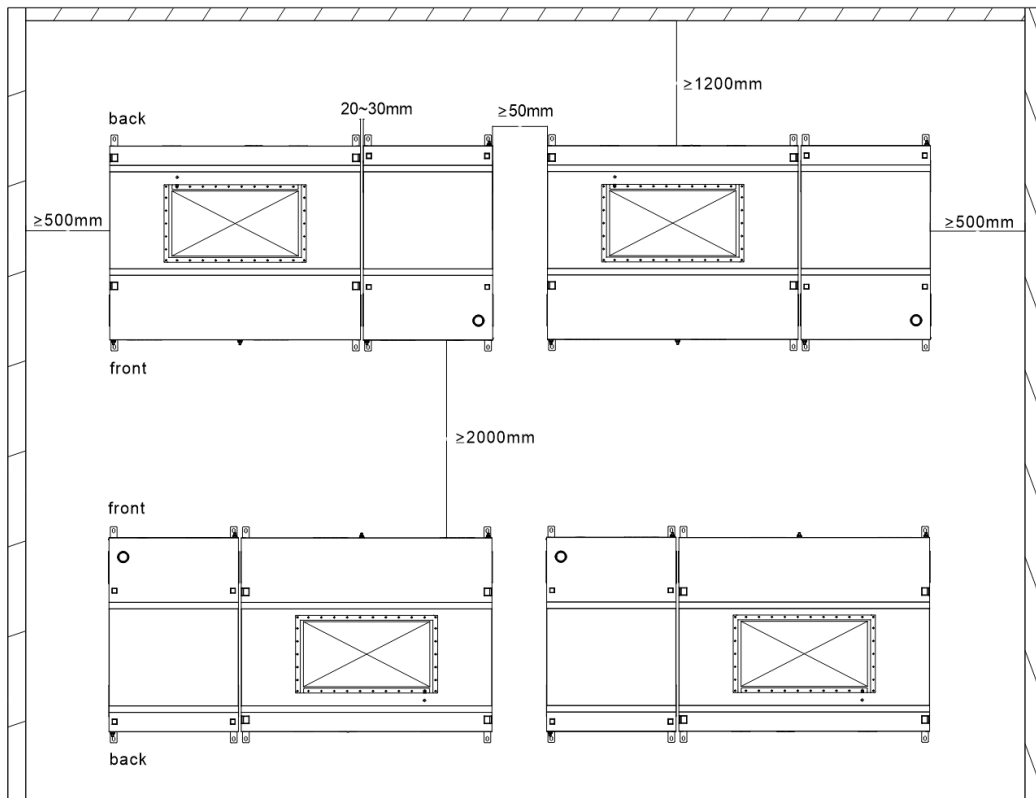
- When installing the Battery Cabinet and AC Cabinet, from the front of the equipment, It is recommended to place AC Cabinet on the right side of Battery Cabinet.
- The following figure shows the minimum space requirements for installation and operation maintenance.



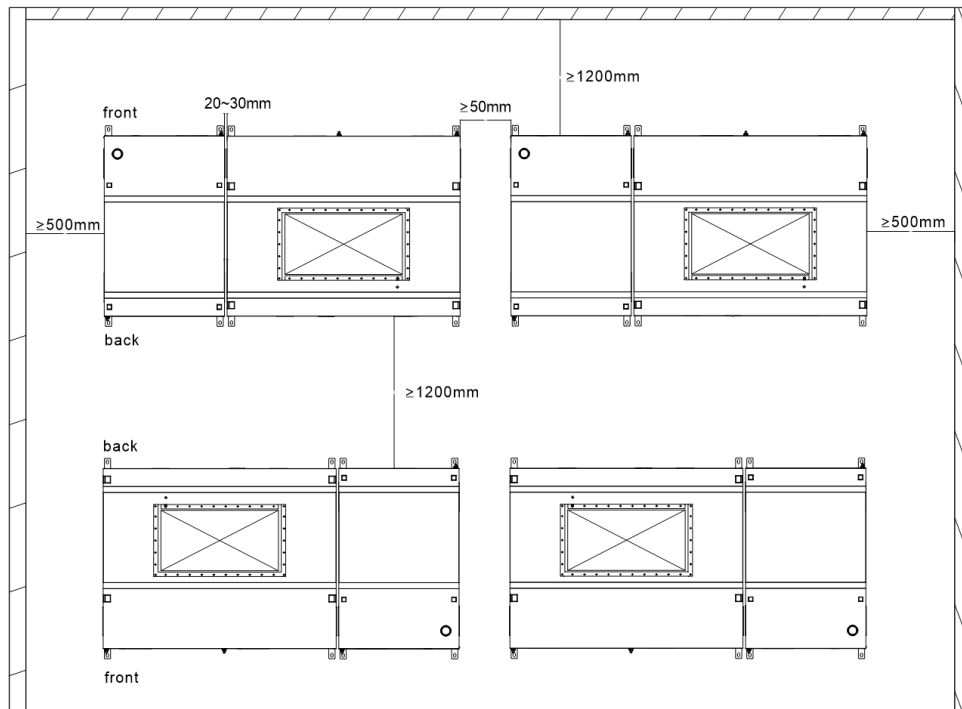
**Figure F-1 Side-by-side installation (top view)**

**BEWARE**

● Regarding the installation layout of on-site equipment, the face-to-face installation mode is not recommended. If this installation method must be used due to special circumstances, please contact our company's after-sales personnel in advance to visit the site for evaluation.



**Figure F-2 Face-to-face installation (top view)**



■ Figure F-3 Back-to-back installation (top view)

## Equipment Installation Instructions

- **Distance between the equipment and the wall:** The horizontal distance between the two sides (lateral sides) of the equipment and the surrounding walls should be  $\geq 500\text{mm}$  to ensure there is enough space for installation, operation, and maintenance.
- **Horizontal spacing between equipment:** If the equipment is installed side by side horizontally, the spacing between them should be controlled at 20 - 30mm; if the equipment is adjacent to other equipment (not side - by - side), the spacing should be  $\geq 50\text{mm}$ .
- **Vertical spacing between upper and lower rows of equipment:** The vertical distance between the upper and lower rows of equipment must be  $\geq 2000\text{mm}$  to meet the space requirements for installation, debugging, and subsequent maintenance. (If the equipment is arranged in a back - to - back installation method, the installation distance between the upper and lower rows can be reduced to  $\geq 1200\text{mm}$ )

# Appendix 1

## 附录 1

巡检项目 Inspection project	方法 Method	是-√ 否-× 不适用-○ Yes-√ No-× Not applicable-○	异常记录 Abnormal record
灭火系统是否完整 Is the fire extinguishing system	目测 Visual inspection		
灭火系统是否在有效期内 Whether the fire extinguishing system is within the validity period	目测 Visual inspection		
散热系统是否完整 Is the chiller system complete	目测 Visual inspection		
散热系统风道是否堵塞 Is the chiller system air duct blocked	目测 Visual inspection		
电柜外观是否变形 Whether the appearance of the electric cabinet is deformed	目测 Visual inspection		
电柜外观是否生锈破损 Whether the appearance of the electric cabinet is rusted or damaged	目测 Visual inspection		
电柜内部是否有水气 Is there water vapor inside the electric cabinet	目测 Visual inspection		
低压线束是否松脱或者破损 Whether the LV harness is loose or damaged	目测 Visual inspection		
高压线束是否松脱或者破损 Whether the HV harness is loose or damaged	目测 Visual inspection		
线束是否与结构件干涉 Whether the wiring harness interferes with the structural parts	目测 Visual inspection		
高压连接是否烧蚀 Whether the high voltage connection is ablated	目测 Visual inspection		

结构件固定螺栓是否松脱或者缺失 Whether the fixing bolt of structural parts is loose or missing	目测 Visual inspection		
液冷管是否破损 Whether the water cooling pipe is damaged	目测 Visual inspection		
电池室内是否有恶臭味 Is there a foul smell in the battery compartment	鼻嗅 Sniffing		
电柜内有无刺激性气味 Is there a pungent smell in the electric cabinet	鼻嗅 Sniffing		
高压连接部位是否有烧焦味 Whether HV connection part has burnt smell	鼻嗅 Sniffing		
概要数据是否齐全 Is the summary data complete	监控上位机 Monitor master computer		
单体电压数据是否齐全 Is the cell voltage data complete	监控上位机 Monitor master computer		
单体温度数据是否齐全 Is the cell temperature data complete	监控上位机 Monitor master computer		
告警栏有无异常报警 Whether there is an abnormal alarm in the alarm bar	监控上位机 Monitor master computer		
<p>说明：巡检中发现任何异常请及时反馈，联系安排相关人员进行处理 Note: If any abnormalities are found during the inspection, please feedback in time, and contact the relevant personnel for processing.</p>			